

JVC

SERVICE MANUAL

COMPACT COMPONENT SYSTEM

MX-K1

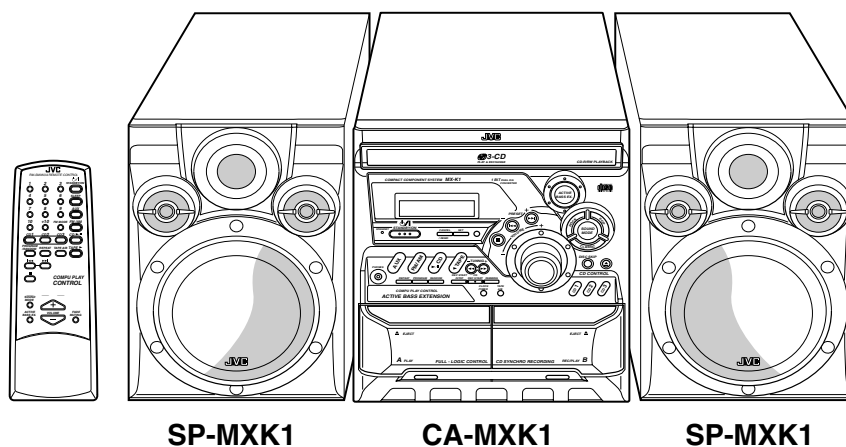

COMPACT
disc
DIGITAL AUDIO

SP-MXK1

CA-MXK1

SP-MXK1

Area Suffix

J U.S.A.
C Canada

Contents

Safety precautions	1-2	Flow of functional	
Important for laser products	1-3	operation until TOC read	1-20
Preventing static electricity	1-4	Maintenance of laser pickup	1-21
Disassembly method	1-5	Replacement of laser pickup	1-21
Adjustment method	1-18	Description of major ICs	1-22

Safety Precautions

1. This design of this product contains special hardware and many circuits and components specially for safety purposes. For continued protection, no changes should be made to the original design unless authorized in writing by the manufacturer. Replacement parts must be identical to those used in the original circuits. Services should be performed by qualified personnel only.
2. Alterations of the design or circuitry of the product should not be made. Any design alterations of the product should not be made. Any design alterations or additions will void the manufacturer's warranty and will further relieve the manufacture of responsibility for personal injury or property damage resulting therefrom.
3. Many electrical and mechanical parts in the products have special safety-related characteristics. These characteristics are often not evident from visual inspection nor can the protection afforded by them necessarily be obtained by using replacement components rated for higher voltage, wattage, etc. Replacement parts which have these special safety characteristics are identified in the Parts List of Service Manual. Electrical components having such features are identified by shading on the schematics and by (\triangle) on the Parts List in the Service Manual. The use of a substitute replacement which does not have the same safety characteristics as the recommended replacement parts shown in the Parts List of Service Manual may create shock, fire, or other hazards.
4. The leads in the products are routed and dressed with ties, clamps, tubings, barriers and the like to be separated from live parts, high temperature parts, moving parts and/or sharp edges for the prevention of electric shock and fire hazard. When service is required, the original lead routing and dress should be observed, and it should be confirmed that they have been returned to normal, after re-assembling.

5. Leakage current check (Electrical shock hazard testing)

After re-assembling the product, always perform an isolation check on the exposed metal parts of the product (antenna terminals, knobs, metal cabinet, screw heads, headphone jack, control shafts, etc.) to be sure the product is safe to operate without danger of electrical shock.

Do not use a line isolation transformer during this check.

- Plug the AC line cord directly into the AC outlet. Using a "Leakage Current Tester", measure the leakage current from each exposed metal parts of the cabinet, particularly any exposed metal part having a return path to the chassis, to a known good earth ground. Any leakage current must not exceed 0.5mA AC (r.m.s.).

- Alternate check method

Plug the AC line cord directly into the AC outlet. Use an AC voltmeter having, 1,000 ohms per volt or more sensitivity in the following manner. Connect a 1,500 Ω 10W resistor paralleled by a 0.15 μ F AC-type capacitor between an exposed metal part and a known good earth ground. Measure the AC voltage across the resistor with the AC voltmeter.

Move the resistor connection to each exposed metal part, particularly any exposed metal part having a return path to the chassis, and measure the AC voltage across the resistor. Now, reverse the plug in the AC outlet and repeat each measurement. Voltage measured any must not exceed 0.75 V AC (r.m.s.). This corresponds to 0.5 mA AC (r.m.s.).

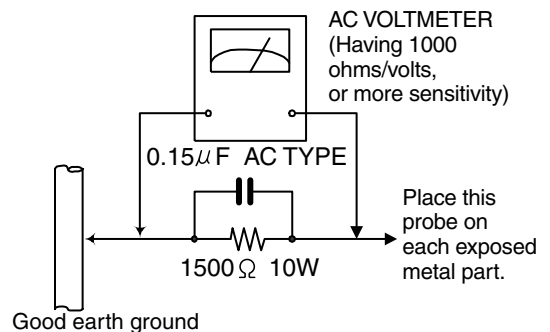

Warning

1. This equipment has been designed and manufactured to meet international safety standards.
2. It is the legal responsibility of the repairer to ensure that these safety standards are maintained.
3. Repairs must be made in accordance with the relevant safety standards.
4. It is essential that safety critical components are replaced by approved parts.
5. If mains voltage selector is provided, check setting for local voltage.

CAUTION

Burrs formed during molding may be left over on some parts of the chassis. Therefore, pay attention to such burrs in the case of preforming repair of this system.

In regard with component parts appearing on the silk-screen printed side (parts side) of the PWB diagrams, the parts that are printed over with black such as the resistor (\blacksquare), diode (\blacksquare) and ICP (\bullet) or identified by the " \triangle " mark nearby are critical for safety.

When replacing them, be sure to use the parts of the same type and rating as specified by the manufacturer. (Except the J and C version)

Important for laser products

1.CLASS 1 LASER PRODUCT

2.DANGER : Invisible laser radiation when open and interlock failed or defeated. Avoid direct exposure to beam.

3.CAUTION : There are no serviceable parts inside the Laser Unit. Do not disassemble the Laser Unit. Replace the complete Laser Unit if it malfunctions.

4.CAUTION : The compact disc player uses invisible laserradiation and is equipped with safety switches which prevent emission of radiation when the drawer is open and the safety interlocks have failed or are defeated. It is dangerous to defeat the safety switches.

5.CAUTION : If safety switches malfunction, the laser is able to function.

6.CAUTION : Use of controls, adjustments or performance of procedures other than those specified herein may result in hazardous radiation exposure.

CAUTION Please use enough caution not to see the beam directly or touch it in case of an adjustment or operation check.

WARNING : Osynlig laserstrålning är denna del är öppnad och spårren är urkopplad. Betrakta ej strålen.

VARO : Avattaessa ja suojalukitus ohitettaessa olet alltiina näkymättömälle lasersäteilylle. Älä katso säteeseen.

ADVARSEL : Usynlig laserstrålning ved åbning , når sikkerhedsafbrydere er ude af funktion. Undgå udsættelse for stråling.

ADVARSEL : Usynlig laserstrålning ved åbning,når sikkerhetsbryteren er avslott. unngå utsettelse for stråling.

REPRODUCTION AND POSITION OF LABELS

WARNING LABEL

DANGER : Invisible laser radiation when open and interlock or defeated. AVOID DIRECT EXPOSURE TO BEAM (e)	VARO : Avattaessa ja suojalukitus ohitettaessa olet alltiina näkymättömälle lasersäteilylle. Älä katso säteeseen. (d)	WARNING : Osynlig laserstrålning är denna del är öppnad och spårren är urkopplad. Betrakta ej strålen. (s)	ADVARSEL : Usynlig laserstrålning ved åbning , når sikkerhedsafbrydere er ude af funktion. Undgå udsættelse for stråling. (f)
--	---	--	---

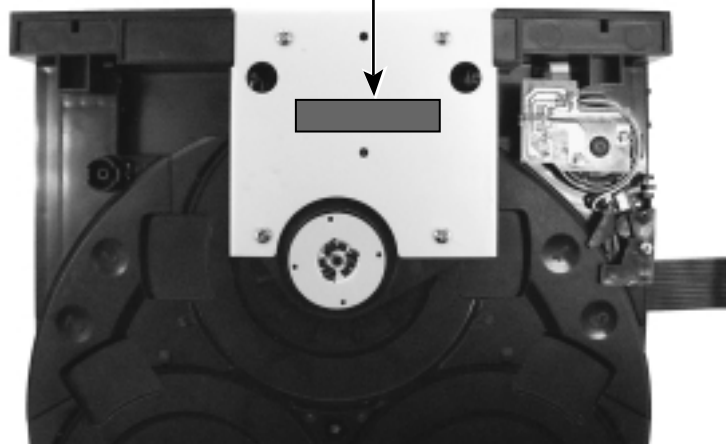

Preventing static electricity

1. Grounding to prevent damage by static electricity

Electrostatic discharge (ESD), which occurs when static electricity stored in the body, fabric, etc. is discharged, can destroy the laser diode in the traverse unit (optical pickup). Take care to prevent this when performing repairs.

2. About the earth processing for the destruction prevention by static electricity

In the equipment which uses optical pick-up (laser diode), optical pick-up is destroyed by the static electricity of the work environment.

Be careful to use proper grounding in the area where repairs are being performed.

2-1 Ground the workbench

Ground the workbench by laying conductive material (such as a conductive sheet) or an iron plate over it before placing the traverse unit (optical pickup) on it.

2-2 Ground yourself

Use an anti-static wrist strap to release any static electricity built up in your body.

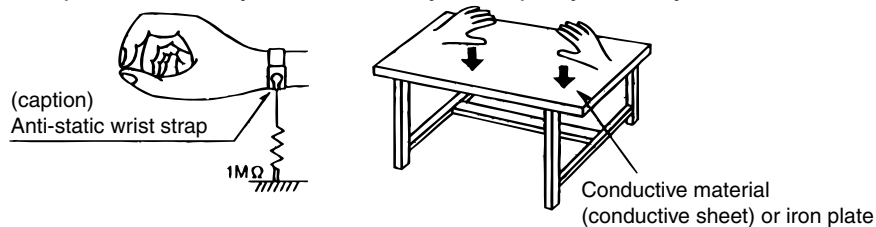

3. Handling the optical pickup

1. In order to maintain quality during transport and before installation, both sides of the laser diode on the replacement optical pickup are shorted. After replacement, return the shorted parts to their original condition. (Refer to the text.)

2. Do not use a tester to check the condition of the laser diode in the optical pickup. The tester's internal power source can easily destroy the laser diode.

4. Handling the CD changer unit (optical pickup)

1. Do not subject the CD changer unit (optical pickup) to strong shocks, as it is a sensitive, complex unit.

2. Cut off the shorted part of the flexible cable using nippers, etc. after replacing the optical pickup. For specific details, refer to the replacement procedure in the text. Remove the anti-static pin when replacing the CD changer unit. Be careful not to take too long a time when attaching it to the connector.

3. Handle the flexible cable carefully as it may break when subjected to strong force.

4. It is not possible to adjust the semi-fixed resistor that adjusts the laser power. Do not turn it



Fig.1

Attention when traverse unit is decomposed

***Please refer to "Disassembly method" in the text for pick-up and how to detach the CD changer mechanism.**

1. Remove the CD changer unit.
2. Disconnect the harness from connector on the CD motor board.
3. Solder is put up before the card wire is removed from connector CN601 on the main board as shown in Fig.1 and Fig. 2.

(When the wire is removed without putting up solder, the CD pick-up assembly might destroy.)

4. Please remove solder after connecting the card wire with CN601 when you install picking up in the substrate.

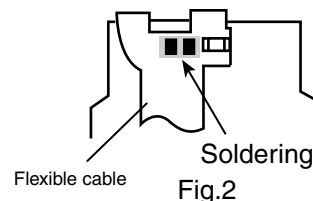

Fig.2

Disassembly method

Commence disassembly of this set by removing the main units and then proceed to the components and assemblies inside the units.

Replacement of the fuses and the power IC

- Top cover
- CD changer unit
- Front panel assembly
- Chassis unit

- CD changer unit
 - Removing the main PCB
 - Removing the CD changer mechanism assembly
 - Removing the CD pickup
 - Replacing the loading motor and belt of the CD changer tray
 - Replacing the CD tray rotor belt of CD changer, and removing the motor

- Front panel assembly
 - Removing the cassette deck mechanism
 - Removing the earphone jack PCB
 - Removing the control/FL PCB
 - Removing the switch PCB and ACTIVE BASS EX. switch PCB
 - Removing the cassette deck main motor, and replacing the main belts
 - Removing the leaf switches of the cassette deck mechanism
 - Removing the cassette deck heads

- Chassis unit
 - Removing the 3-pin regulator
 - Removing the power amp and supply PCB and the Power Trans PCB

<Disassembly of the main blocks of this set>

Replacement of the fuses and the power IC**■ Replacing the fuses (See Fig.1)**

- Prior to performing the following procedure, remove the top cover.
1. Replace the fuses inside.

[Caution] Be sure to use fuses with the specified ratings.

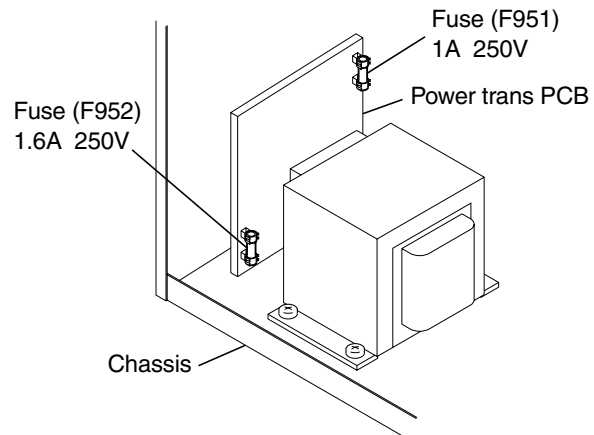

Fig.1

■ Replacing the power IC (See Fig.2 and 3)

- Prior to performing the following procedure, remove the top cover.
 - Also remove the rear panel. (See Fig.33)
1. Remove the screw "A" from the bracket that retains the power IC.
 2. Remove the solder fixing the power IC.

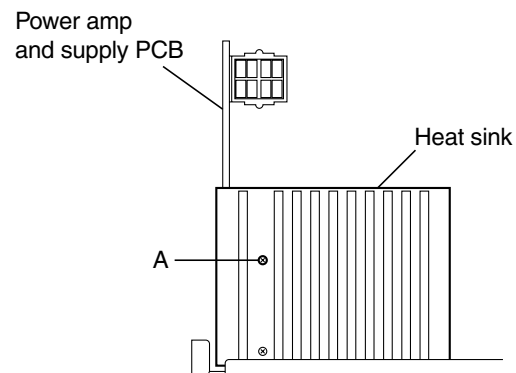

Fig.2

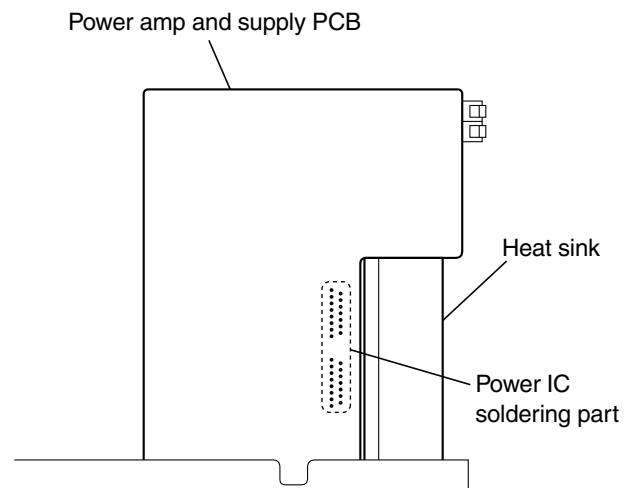

Fig.3

■ Removing the top cover
(See Fig.4 and 5)

1. Remove the six screws "B" that retain the top cover from the rear of the body.
2. Remove the four screws "C" that retain the top cover from the two sides of the body.
3. Remove the top cover from the body by lifting it toward the rear.

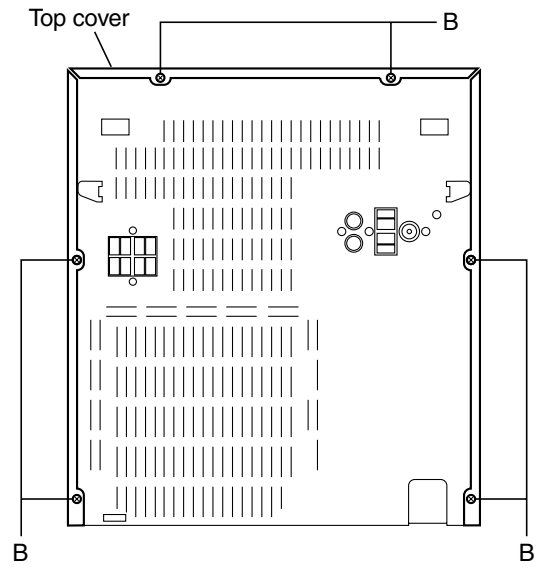

Fig.4

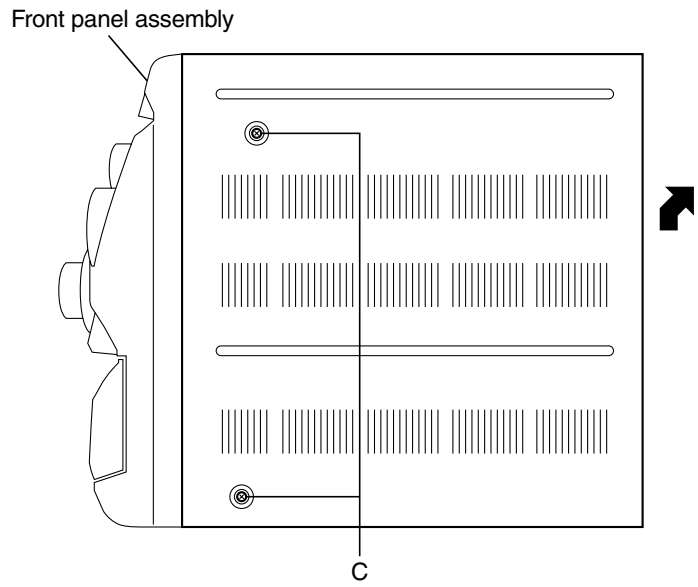

Fig.5

■ Removing the CD changer unit (See Fig.6 to 9)

- Prior to performing the following procedures, remove the top cover.

[Caution] Although the CD mechanism unit can be removed without removing the CD tray panel, it is still recommended to remove it in order to prevent damage.

- From the front panel side of this set, push in the sections marked with arrows and pull out the CD tray toward the front.
 - Remove the CD tray panel by pushing both of its extremities upward in the direction of the arrows.
 - Push the CD tray deep into the set.
- Disconnect the cassette head wires from the connectors CN307 and CN308 on the main PCB, which is located below the CD changer unit.
 - Disconnect the card wires from the connectors CN301, CN302 and CN305 on the main PCB.
 - Disconnect the parallel wires from the connectors CN902A, CN902B and CN902C on the power amp and supply PCB.
 - From the rear of the set, remove the two screws "D" retaining the CD changer unit, then remove the three screws "E" and the screw "F" retaining the ANTENNA terminal and the AUX IN terminal.
 - Push down and disengage the two claws "a" holding the CD changer unit at the bottom of its front panel and then remove the CD changer unit (Fig. 9).

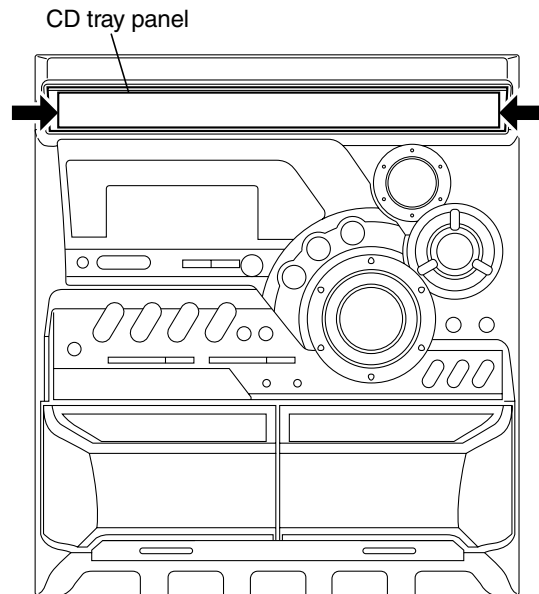

Fig.6

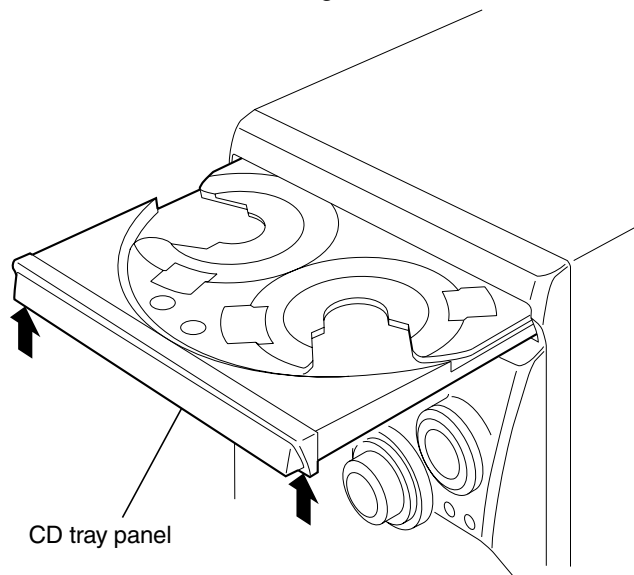

Fig.7

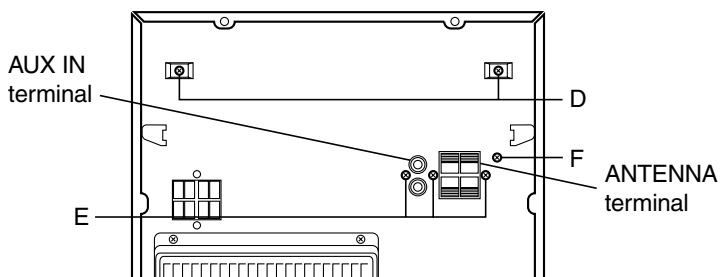

Fig.8

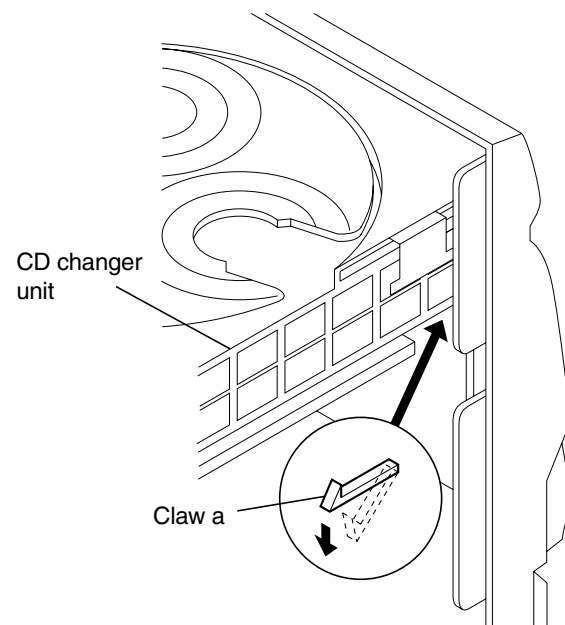

Fig.9

■ Removing the front panel assembly (See Fig.10 and 11)

- Prior to performing the following procedures, remove the top cover.
 - Also remove the CD changer unit.
1. Disconnect the parallel wire and card wire from the connectors CN101 and CN901 on the power amp and supply PCB.
 2. Remove the two screws "G" retaining the front panel assembly onto the bottom of the body.
 3. Remove the screw "H" retaining the cassette deck mechanism and then remove the GND lug "b" that comes from the power amp and supply PCB.
 4. Remove the solder connecting the wire on the control/FL PCB.
 5. Disengage the claws "c" on both sides at the bottom of the front panel assembly and then remove the assembly.

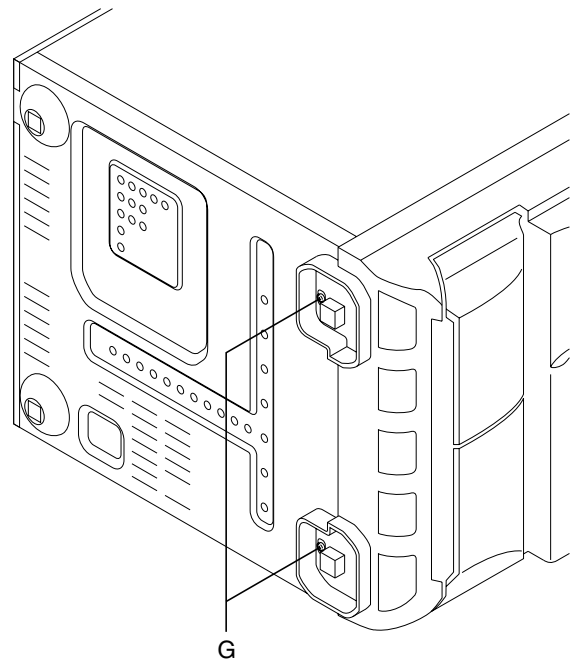

Fig.10

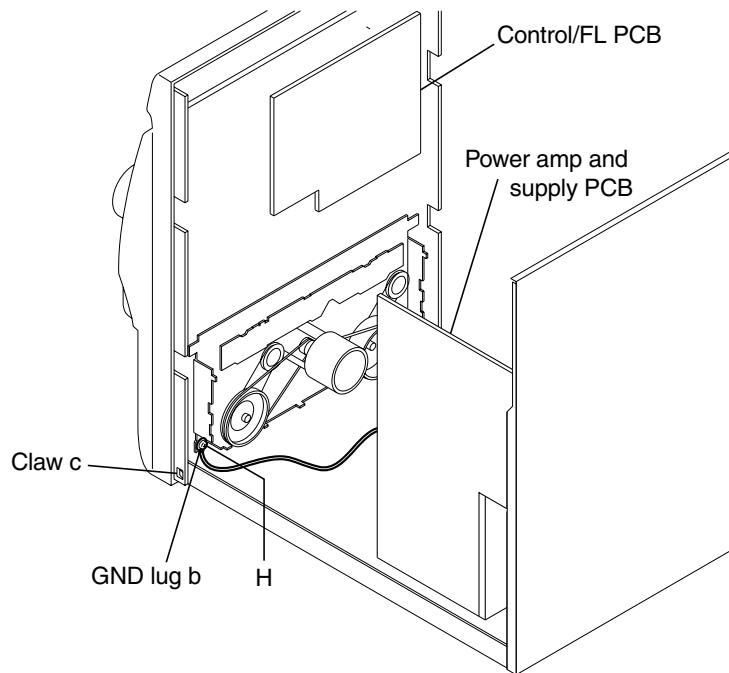

Fig.11

<Disassembly of units and assembly inside this set>

■ Removing the main PCB

(See Fig.12 and 13)

- Prior to performing the following procedures, remove the top cover.
 - Also remove the CD changer unit.
1. Disconnect the wires from CN602 and CN603 on the main PCB, which is located on the backside of the CD changer unit.
 2. Disconnect the card wire from connector CN604 of the main PCB at the back of the CD changer unit.
 3. The three screws "I" and the screw with the washer "J" that retain the main PCB should be removed.
 4. Remove the main PCB by pulling it toward the side where the CN601 is located.
 5. Using solder, short the CD pickup to connect to short round.

[Caution] After re-connecting the wires, be sure to remove the shorting solder from the GND connection.

6. Disconnect the card wire from the connector CN601 on the main PCB and then remove the main PCB.

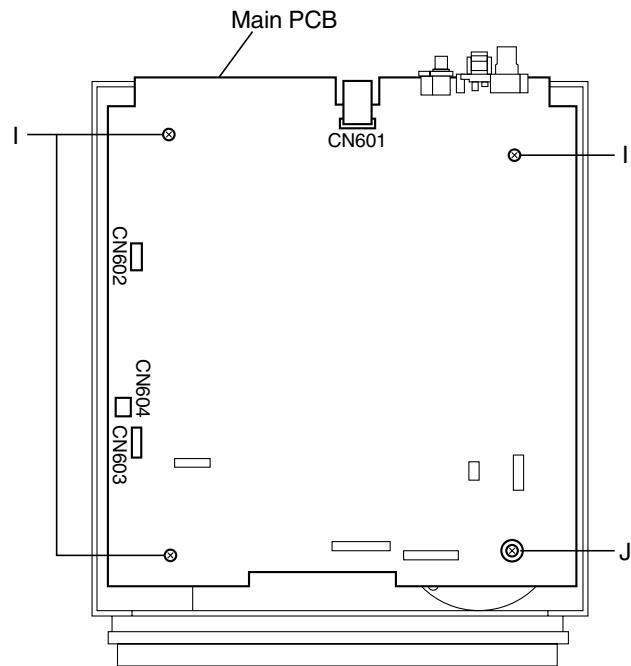

Fig.12

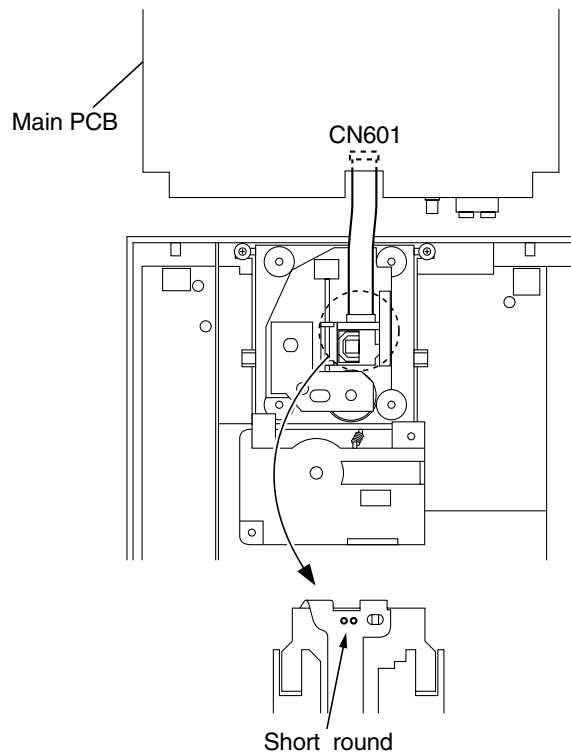

Fig.13

■ Removing the CD changer mechanism assembly (See Fig.14 to 16)

- Prior to performing the following procedures, remove the top cover.
 - Also remove the CD changer unit.
1. Remove the spring "d" from the front surface of the CD changer mechanism unit.
 2. Turn the CD changer mechanism unit upside down, and remove the spring "e" connecting the unit to the CD changer mechanism assembly.

[Note] When re-assembling after the disassembly work, apply bonding agent on the spring to prevent it from slipping off.

3. Remove the two screws "K" retaining the CD changer mechanism assembly.

[Caution] When replacing the CD changer mechanism assembly, be sure not to mistake the positions of the red and blue dampers.

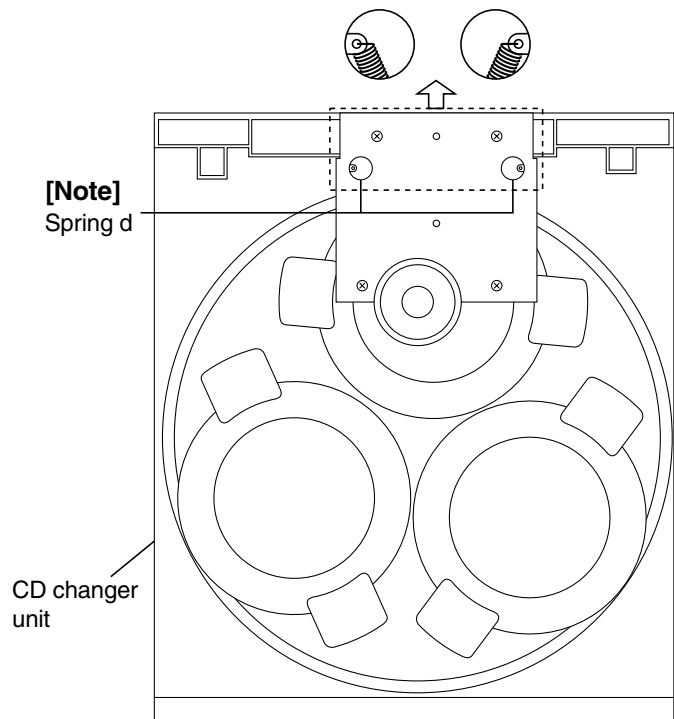

Fig.14

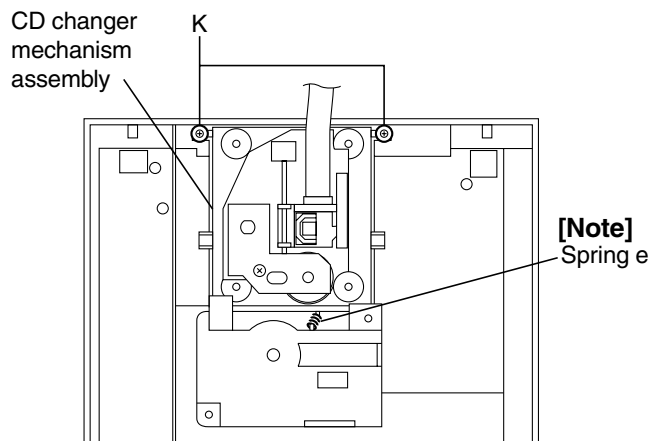

Fig.15

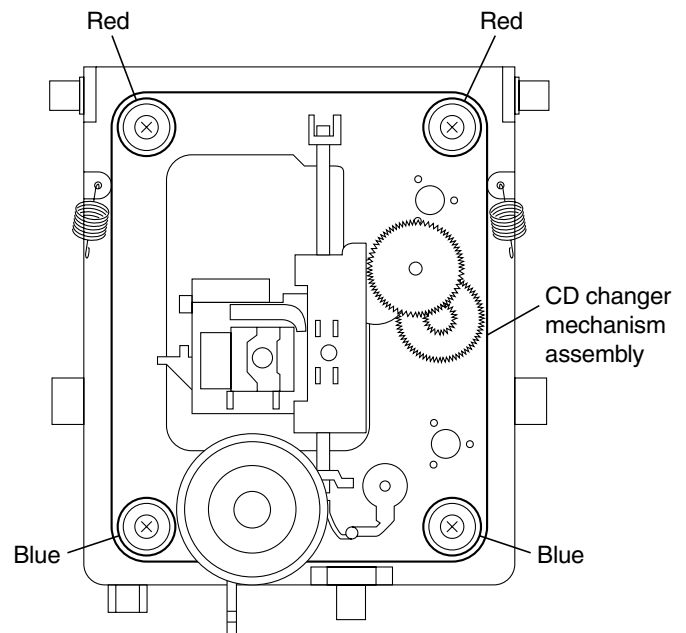
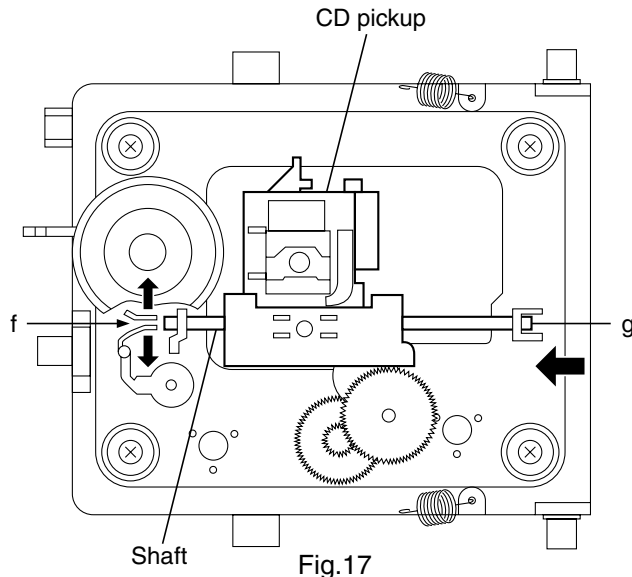

Fig.16

■ Removing the CD pickup (See Fig.17)

- Prior to performing the following procedures, remove the top cover.
- Also remove the CD changer unit.
- Also remove the CD changer mechanism

1. Widen the section "f".
2. While keeping the section "f" wide open, push the section "g" in the direction of the arrow to remove the shaft, and then remove the CD pickup.



■ Replacing the loading motor and belt of the CD changer tray (See Fig.18)

- Prior to performing the following procedure, remove the top cover.

1. Pull out the CD changer tray.
2. Remove the belt from the pulley.
3. Remove the two screws "L" retaining the CD changer tray loading motor.

[Caution] When pushing in the CD changer tray, be sure to lower the CD changer mechanism assembly by manually turning the UD cam gear in the direction of the arrow.

■ Replacing the CD tray rotor belt of the CD changer, and removing the motor (See Fig.19 and 20)

- Prior to performing the following procedures, remove the top cover.
- Also remove the CD changer unit.

1. Remove the two screws "M" retaining the stopper brackets on both sides of the CD changer unit.
2. Remove the stopper brackets from both sides of the CD changer unit.
3. Pull out the CD tray from the CD changer unit, all the way and then lift the tray upward to remove.
4. Turn the CD tray upside down and remove the tray rotor belt from the pulley.
5. Turn the CD tray upside down and disconnect the card wire from the connector CN605 on the CD tray rotor motor assembly.
6. Remove the two screws "N" retaining the CD tray rotor motor, and then remove the CD tray rotor motor.

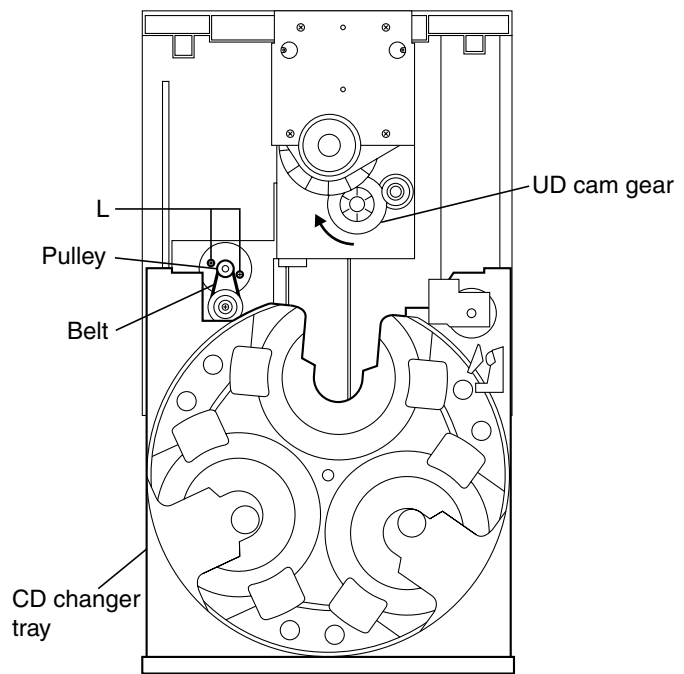

Fig.18

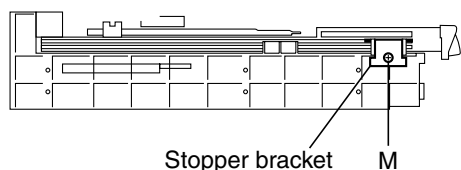

Fig.19

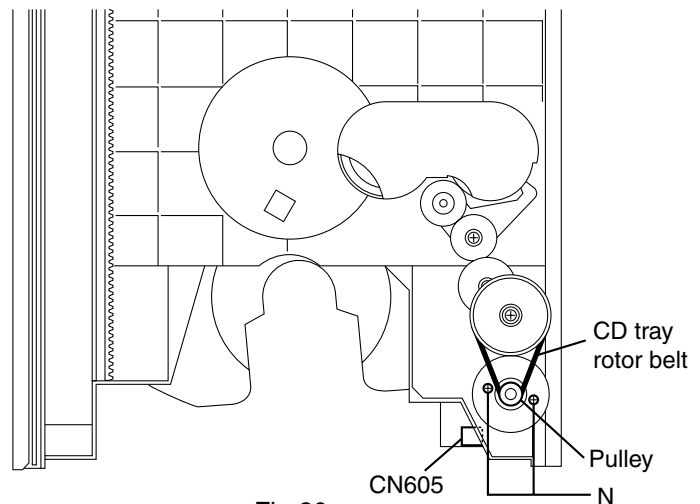

Fig.20

■ Removing the cassette deck mechanism (See Fig.21)

- Prior to performing the following procedure, remove the top cover.
- Also remove the CD changer unit.
- Also remove the front panel assembly.

1. Remove the five screws "O" retaining the cassette deck mechanism from the back of the front panel assembly.

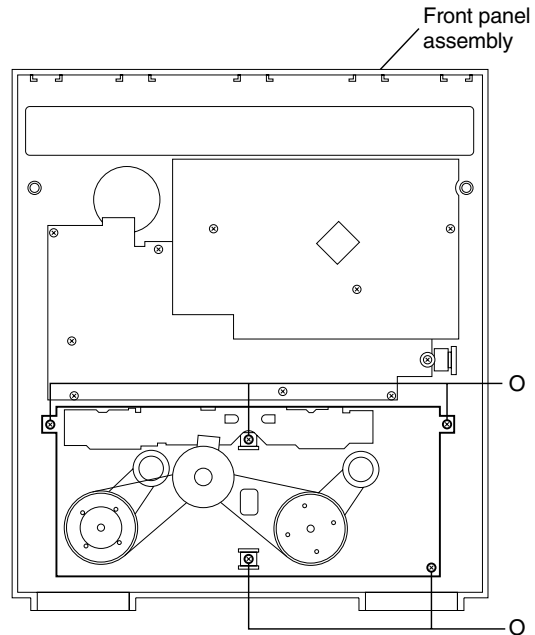

Fig.21

■ Removing the earphone jack PCB (See Fig.22)

- Prior to performing the following procedure, remove the top cover
- Also remove the CD changer unit.
- Also remove the front panel assembly.

1. Remove the screw with the washer, "P" that retains the earphone jack PCB from the back of the front panel assembly.

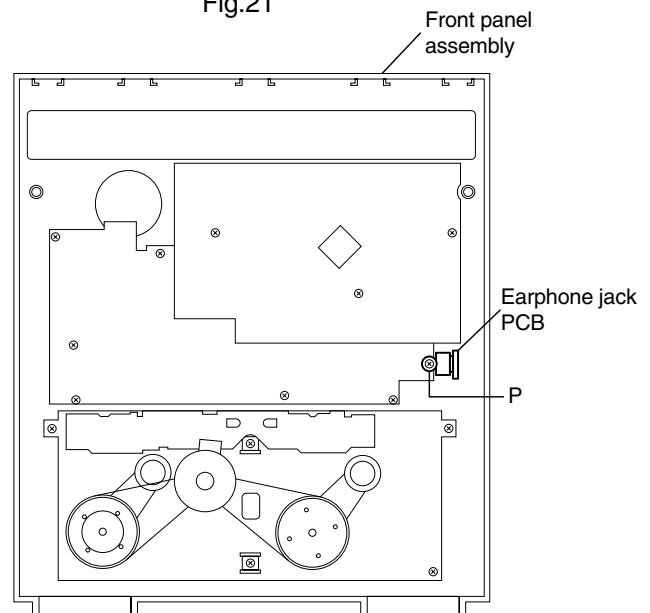

Fig.22

■ Removing the control/FL PCB (See Fig.23)

- Prior to performing the following procedure, remove the top cover.
- Also remove the CD changer unit.

1. Remove the three screws "Q" that retain the control/FL PCB from the back of the front panel assembly.

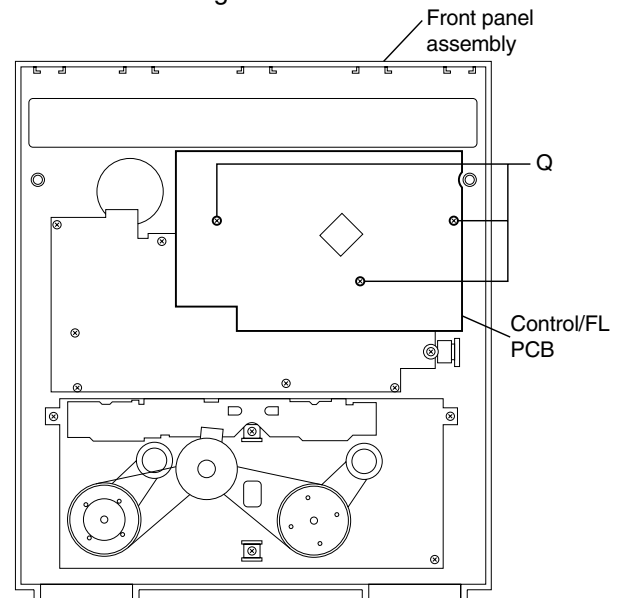

Fig.23

■ **Removing the switch PCB and ACTIVE BASS EX. switch PCB (See Fig.23 to 26)**

- Prior to performing the following procedures, remove the top cover.
 - Also remove the CD changer unit.
 - Also remove the front panel assembly.
1. Pull out the volume control knob from the front of the front panel assembly.
 2. Remove the nut and washer retaining the volume knob shaft.
 3. Remove the three screws "Q" retaining the control/FL PCB from the back of the front panel assembly.
 4. Remove the control/FL PCB.
 5. Remove the eleven screws "R" retaining the switch PCB.
 6. Remove the two screws "S" retaining the ACTIVE BASS EX. switch PCB.

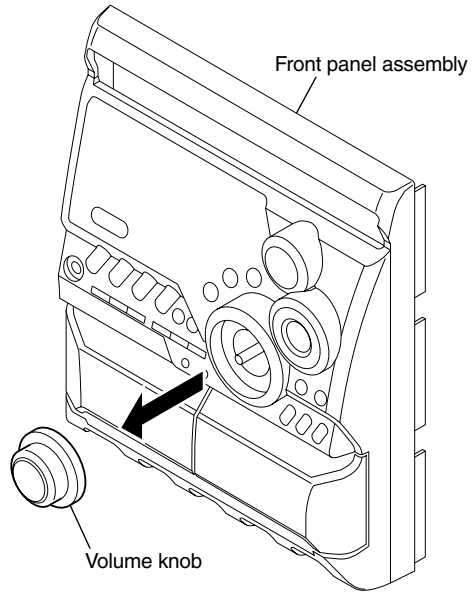

Fig.24

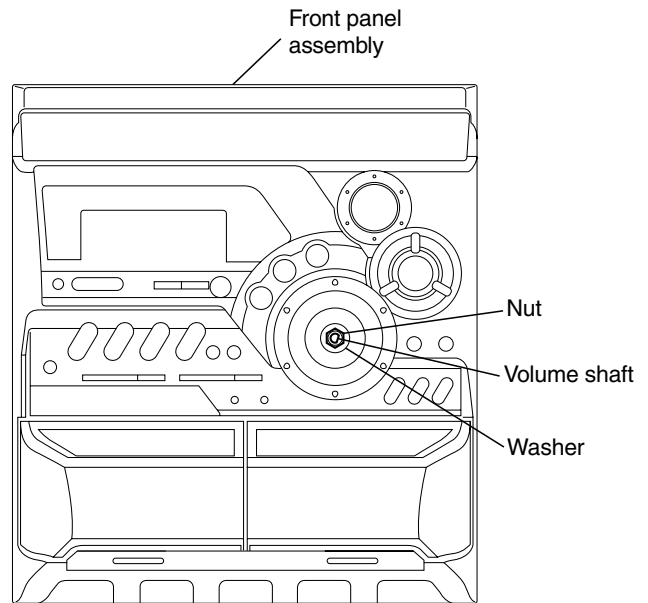

Fig.25

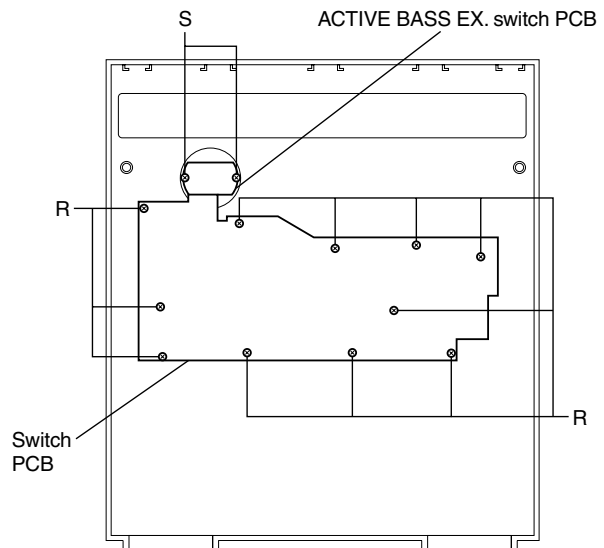

Fig.26

■ Removing the cassette deck main motor, and replacing the main belts (See Fig.21, 27 and 28)

- Prior to performing the following procedures, remove the top cover.
 - Also remove the CD changer unit.
 - Also remove the front panel assembly.
1. Remove the five screws "O" retaining the cassette deck mechanism.
 2. Remove the cassette deck mechanism.
 3. Remove the two screws "T" retaining the main motor from the front side of the cassette deck.

[Caution] After attaching the main motor, check the orientation of the motor and the polarity of the wires.

4. From the backside of the cassette deck, remove the main motor and two main belts.

[Caution] The lengths of the cassette A (playback only) and cassette B (record/play) main belts are different. When attaching the main belts, use the longer belt for cassette A.

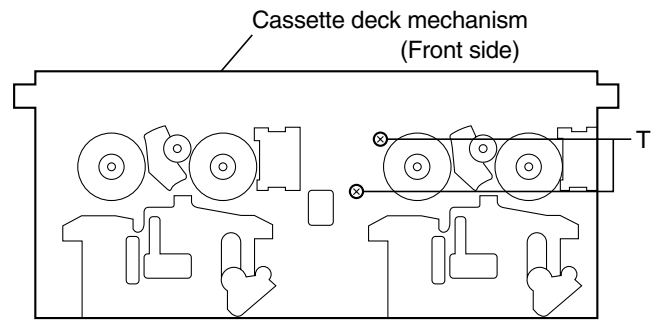

Fig.27

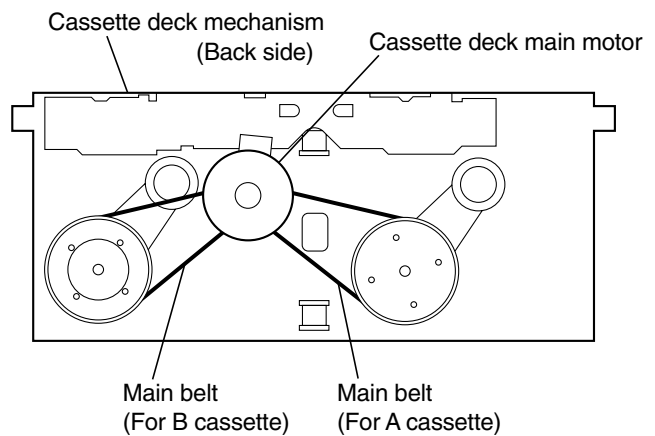

Fig.28

■ Removing the leaf switches of the cassette deck mechanism (See Fig.21 and 29)

- Prior to performing the following procedures, remove the top cover.
 - Also remove the CD changer unit.
 - Also remove the front panel assembly.
1. Remove the five screws "O" that retain the cassette deck mechanism.
 2. Remove the cassette deck mechanism.
 3. Turn the cassette deck mechanism upside down.
 4. Remove the solder from around the leaf switches.
 5. Pull out the leaf switches from the front side of the cassette deck mechanism.

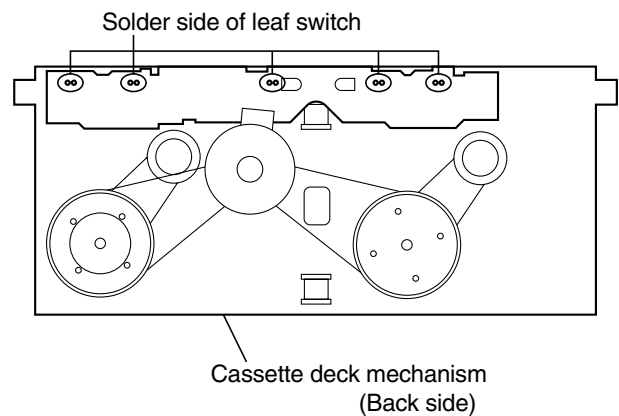

Fig.29

■ Removing the cassette deck heads (See Fig.21 and 30)

- Prior to performing the following procedures, remove the top cover.
 - Also remove the CD changer unit.
 - Also remove the front panel assembly.
1. Remove the five screws "O" that retain the cassette deck mechanism.
 2. Remove the cassette deck mechanism and place it so that the front side faces up.
 3. Remove the solder from the bottom side of the head terminal and disconnect the wire.
 4. Remove the screw "U" that retains the head.
 5. Loosen the screw "V" that retains the head.
 6. Hold the head and slide it in the direction of the arrow to remove it.

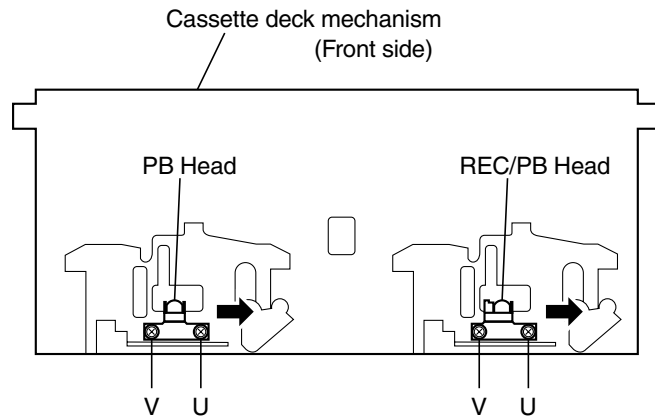

Fig.30

■ Removing the 3-pin regulator (See Fig.31 and 32)

- Prior to performing the following procedures, remove the top cover.
 - Also remove the rear panel. (See Fig.33)
1. Remove the screw "W" that retains the bracket holding the 3-pin terminal regulator.
 2. Remove the solder fixing the 3-pin regulator.

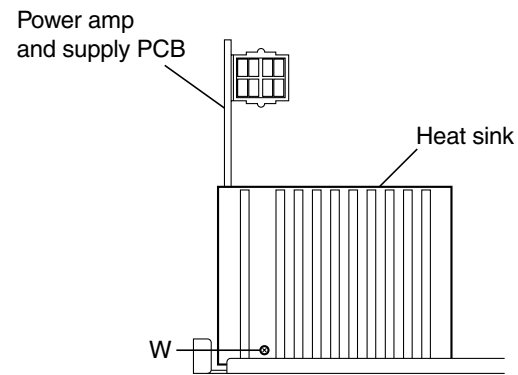

Fig.31

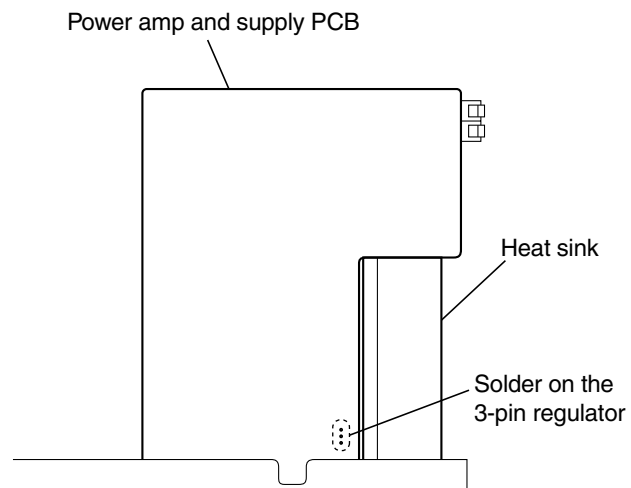

Fig.32

■ Removing the power amp and supply PCB and the power trans PCB (See Fig.33 to 37)

- Prior to performing the following procedures, remove the top cover.
 - Also remove the CD changer unit.
1. Remove the two screws "X" that retain the SPEAKERS terminals.
 2. Remove the screw "Y" that retains the rear panel, and then remove the rear panel.
 3. Disconnect the parallel wires from the connectors CN901A and CN901B on the power amp and supply PCB.
 4. Disconnect the parallel wire and card wire from the connectors CN101 and CN901 on the power amp and supply PCB.
 5. Remove the three screws "Z" retaining the heat sink onto the bottom of the chassis.
 6. Remove the screw "AA" that retain the power amp and supply PCB and then remove the assembly.
 7. Remove the clamp of AC power cord from the chassis.
 8. Remove the four screws "AB" that retain the power trans PCB and then remove the assembly.

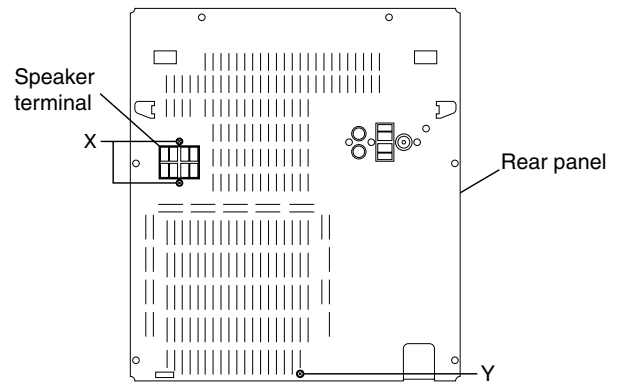

Fig.33

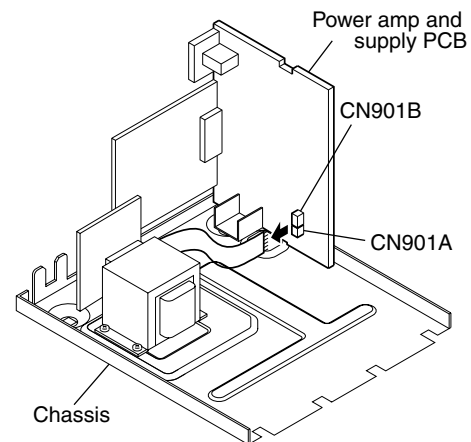

Fig.34

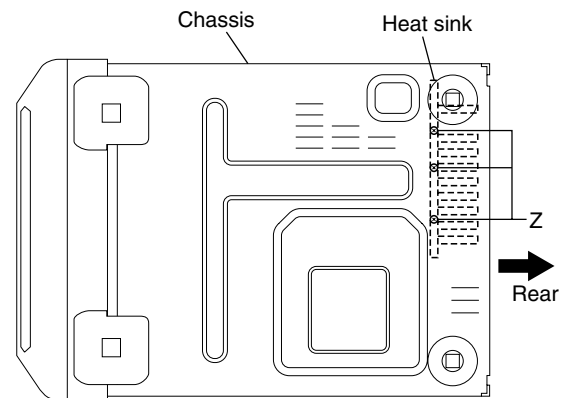

Fig.35

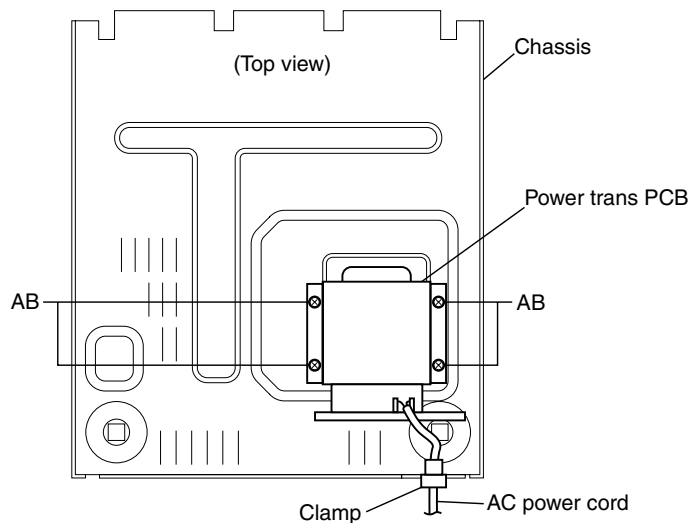

Fig.37

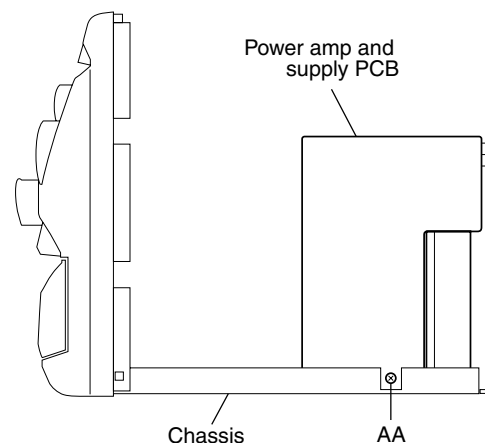

Fig.36

Adjustment method

Measurement instruments required for adjustment

1. Low frequency oscillator,
This oscillator should have a capacity to output 0dB to 600ohm at an oscillation frequency of 50Hz-20kHz.
2. Attenuator impedance : 600ohm
3. Electronic voltmeter
4. Frequency counter
5. Wow flutter meter
6. Test tape
VT712 : For Tape speed and wow flutter (3kHz)
VT703 : For Head angle(10kHz),Play back frequency characteristics(1kHz),and dubbing frequency characteristics(63,1,10kHz)
7. Blank tape
TAPE I : AC-225, TAPE II : AC-514
8. Torque gauge : For play and back tension
Forward ; TW2111A, Reverse ; TW2121A
Fast Forward and Rewind ; TW2231A
9. Test disc
: CTS-1000(12cm),GRG-1211(8cm)
10. Jitter meter

Measurement conditions

Power supply voltage
AC120V (60Hz)

Measurement
output terminal : Speaker out
: TP101(Measuring for TUNER/DECK/CD)
: Dummy load 6ohm

Radio input signal

AM modulation frequency : 400Hz
Modulation factor : 30%
FM modulation frequency : 400Hz
Frequency displacement : 22.5kHz

Frequency Range

AM 531kHz~1710kHz
FM 87.5MHz~108MHz

Standard measurement positions of volume and switch

Power : Standby (Light STANDBY Indicator)
S,A,BASS : OFF
Sound mode : OFF
Main VOL. : 0 Minimum
Travers mecha set position : Disc 1
Mic MIX VOL : MAX
ECHO : OFF

Precautions for measurement

1. Apply 30pF and 33kohm to the IF sweeper output side and 0.082 μ F and 100kohm in series to the sweeper input side.
2. The IF sweeper output level should be made as low as possible within the adjustable range.
3. Since the IF sweeper is a fixed device, there is no need to adjust this sweeper.
4. Since a ceramic oscillator is used, there is no need to perform any MPX adjustment.
5. Since a fixed coil is used, there is no need to adjust the FM tracking.
6. The input and output earth systems are separated. In case of simultaneously measuring the voltage in both of the input and output systems with an electronic voltmeter for two channels, therefore, the earth should be connected particularly.
7. In the case of BTL connection amplifier, the minus terminal of speaker is not for earthing. Therefore, be sure not to connect any other earth terminal to this terminal. This system is of an OTL system.

■ Arrangement of adjusting positions

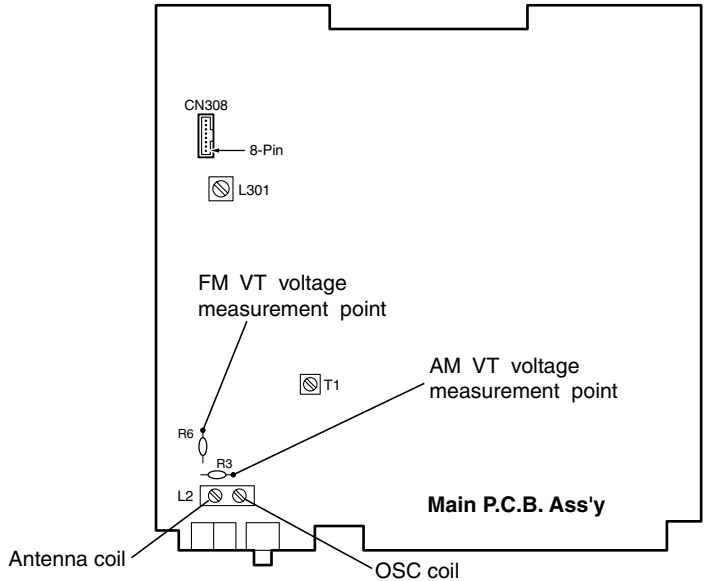
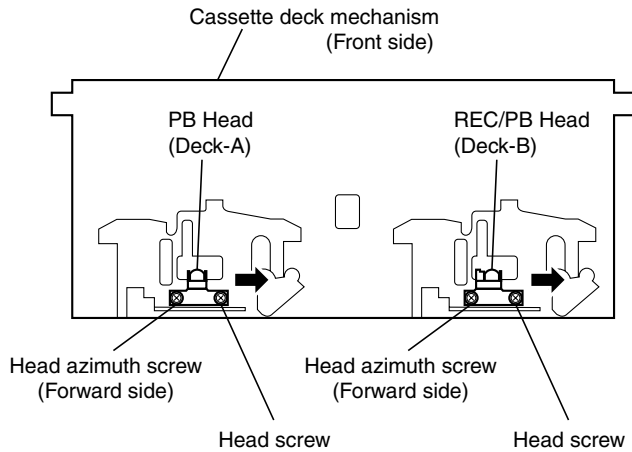

■ Tape recorder section

Items	Measurement conditions	Measurement method	Standard values	Adjusting positions
Cassette Head Azimuth Alignments	Test tape : VT703 (10kHz) Measurement output terminal : Left and Right speaker output (6-ohm loaded) or Headphone Output (32-ohm loaded)	1. Playback the test tape VT703 (10kHz) or equivalent. 2. Adjust the head azimuth screw to obtain maximum output and both output of L / R is in 3dB. 3. Put on the screw lock paint after alignments.	Maximum output	Head azimuth screw Adjust the head azimuth screw only when the head has been changed.
Recording Bias Frequency Alignment	Test tape : TYPE II AC-514 Measurement output terminal : Erase head terminal (CN308 8-Pin)	1. Insert the recording tape in deck-B. 2. Starting the recording. 3. Adjust the oscillation frequency to 80kHz \pm 3kHz by core of Oscillation coil of L301.	80kHz \pm 3kHz	Bias coil: L301 Use the High-Impedance Probe for Frequency counter input.

■ Tuner section

Items	Measurement conditions	Measurement method	Standard values	Adjusting positions
AM Tracking Alignments	Input signal : 530kHz Measurement point : Resistor R3 (AM) Resistor R6 (FM)	OSC coil adjustment 1. Set the Signal Generator signal to 530kHz the feed to Loop Antenna. 2. Receiving the signal and the adjust the OSC coil (L2) obtain the V.T is 1.40V \pm 0.05V.	V.T : 1.40V \pm 0.05V	OSC/Antenna coil : L2 Adjust the OSC coil only when the AM coil block has been changed.
	Input signal : 600kHz	Antenna coil check or adjustment 1. Change the receiving frequency to 600kHz. 2. Adjust the Antenna coil (L2) obtain maximum sensitivity. (Adjust the SSG output to out of AGC range.)	Maximum sensitivity	
AM IFT Alignments	Input signal : 530kHz	1. Set the receiving frequency to 530kHz. 2. Feed the 450kHz signal to AM IF input. 3. Adjust the IFT Block T1 obtain to maximum output. (Adjust the SSG output to out of AGC range.)	Maximum output	IFT (T1) Adjust the IFT only when the IFT block has been changed.

Note: The adjustment of CD section is not required.

Flow of functional operation until TOC read

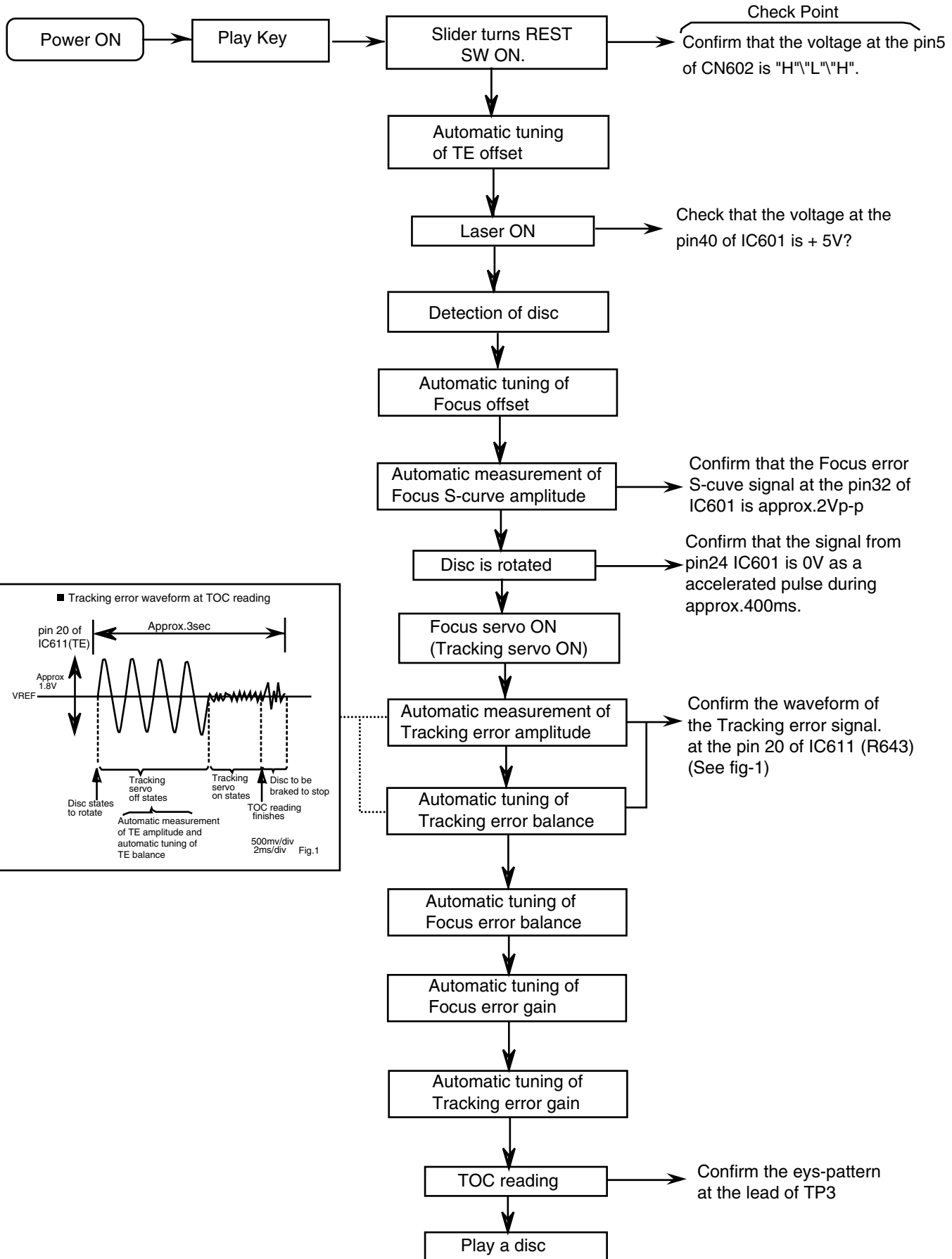

Maintenance of laser pickup

- (1) Cleaning the pick up lens
Before you replace the pick up, please try to clean the lens with a alcohol soaked cotton swab.
- (2) Life of the laser diode
When the life of the laser diode has expired, the following symptoms will appear.
 1. The level of RF output (EFM output: amplitude of eye pattern) will below.

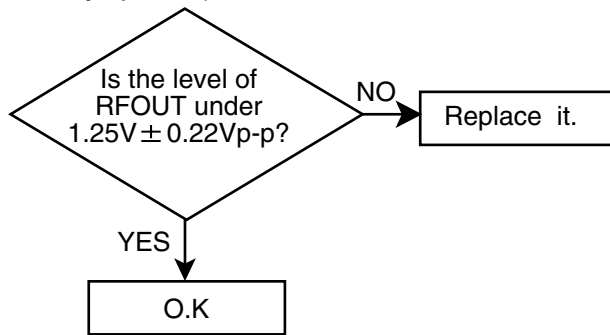

Replacement of laser pickup

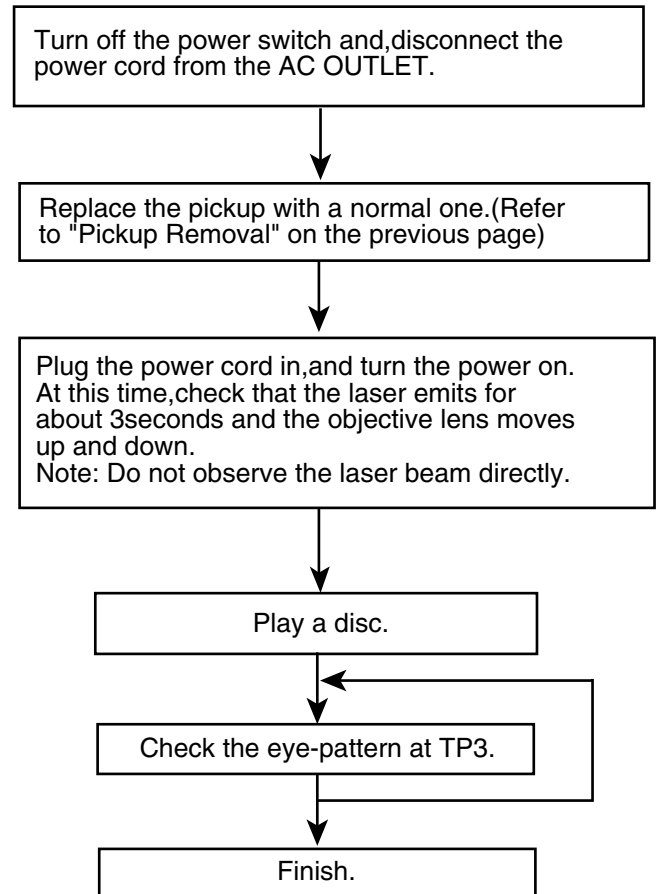

(3) Semi-fixed resistor on the APC PC board

The semi-fixed resistor on the APC printed circuit board which is attached to the pickup is used to adjust the laser power. Since this adjustment should be performed to match the characteristics of the whole optical block, do not touch the semi-fixed resistor.

If the laser power is lower than the specified value, the laser diode is almost worn out, and the laser pickup should be replaced.

If the semi-fixed resistor would be adjusted when the pickup operates normally, the laser pickup may be damaged due to excessive current.

Description of major ICs

■ AN22000A (IC611) : CD-DA Head Amp.

1. Terminal layout

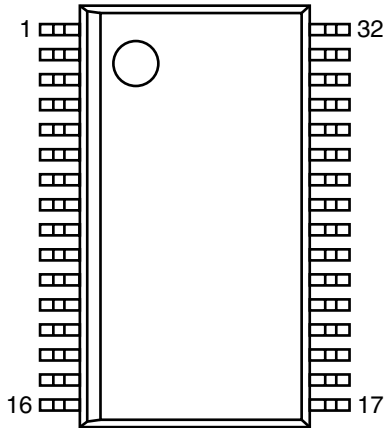

2. Pin function

Pin No.	Symbol	I/O	Function	Pin No.	Symbol	I/O	Function
1	PD	I	APC Amp. input terminal	15	NRFDET	O	NRFDET output terminal
2	LD	O	APC Amp. output terminal	16	GND	-	Ground
3	VCC	-	Power supply terminal	17	VREF	O	VREF output terminal
4	RFN	I	RF adder Amp. inverting input terminal	18	VDET	O	VDET output terminal
5	RFOUT	O	RF adder Amp. output terminal	19	TEBPF	I	VDET output terminal
6	RFIN	I	AGC input terminal	20	TEOUT	O	TE Amp. output terminal
7	CAGC	I	Input terminal for AGC loop filter capacitor	21	TEN	I	TE Amp. inverting input terminal
8	ARF	O	AGC output terminal	22	FEN	I	FE Amp. inverting input terminal
9	CBA	I	Capacitor connecting terminal for HPF-Amp.	23	FEOUT	O	FE Amp. output terminal
10	3TOUT	O	3 TENV output terminal	24	GCTL	O	GCTL & APC terminal
11	CBOO	I	Capacitor connecting terminal for envelope detection on the darkness side	25	FBAL	O	FBAL control terminal
12	BDO	O	BDO output terminal	26	TBAL	O	TBAL control terminal
13	COFTR	I	Capacitor connecting terminal for envelope detection on the light side	27	E	I	Tracking signal input terminal 1
14	OFTR	O	OFTR output terminal	28	F	I	Tracking signal input terminal 2
				29	D	I	Focus signal input terminal 4
				30	B	I	Focus signal input terminal 3
				31	C	I	Focus signal input terminal 2
				32	A	I	Focus signal input terminal 1

3. Block diagram

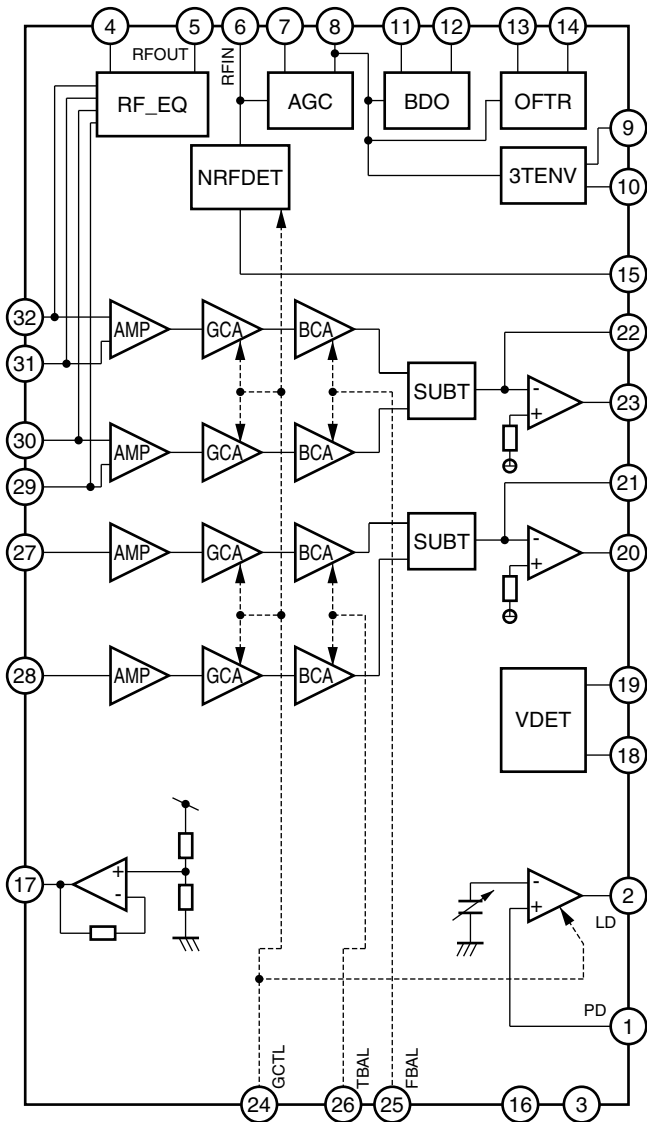

■ **BA15218 (IC102) : Dual low noise operational amp.**

1. Terminal layout

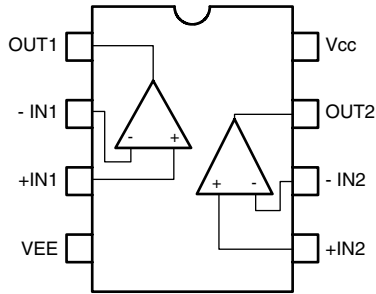

■ **BA5936S (IC621) : 6 channel BTL driver**

1. Block diagram

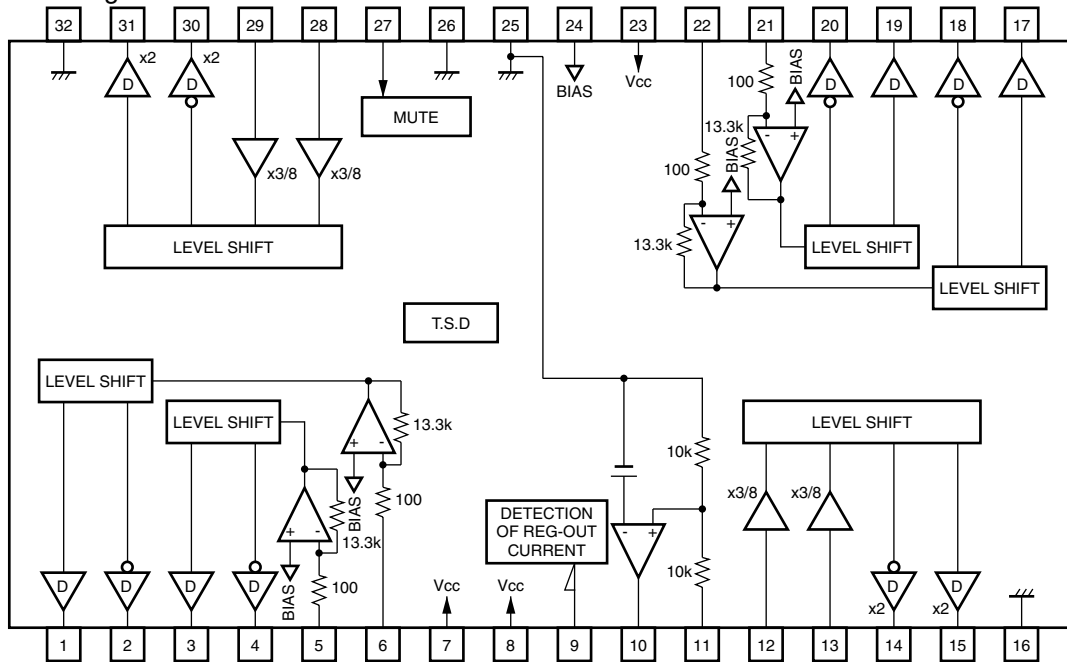

2. Pin function

Pin No.	Symbol	I/O	Function	Pin No.	Symbol	I/O	Function
1	OUT1-	O	CH1 negative output	17	OUT4-	O	CH4 negative output
2	OUT1+	O	CH1 positive output	18	OUT4+	O	CH4 positive output
3	OUT2-	O	CH2 negative output	19	OUT5-	O	CH5 negative output
4	OUT2+	O	CH2 positive output	20	OUT5+	O	CH5 positive output
5	IN2	I	CH2 input	21	IN5	I	CH5 input
6	IN1	I	CH1 input	22	IN4	I	CH4 input
7	VCC	-	Power supply terminal	23	VCC	-	Power supply terminal
8	VCC	-	Power supply terminal	24	BIAS IN	I	Bias input terminal
9	REG-I	I	Regulator current detection terminal	25	GND	-	Ground
10	REG-B	O	Connect to base terminal of external transistor	26	GND	-	Ground
11	REG-OUT	O	Constant voltage output (Connect to collector terminal of external transistor)	27	MUTE IN	I	Mute input terminal
12	IN3-R	I	CH3 reverse input	28	IN6-R	I	CH6 reverse input
13	IN3-F	I	CH3 forward input	29	IN6-F	I	CH6 forward input
14	OUT3+	O	CH3 positive output	30	OUT6+	O	CH6 positive output
15	OUT3-	O	CH3 negative output	31	OUT6-	O	CH6 negative output
16	GND	-	Ground	32	GND	-	Ground

■ LA1823 (IC1) : 1chip AM/FM, MPX tuner system

1. Block diagram

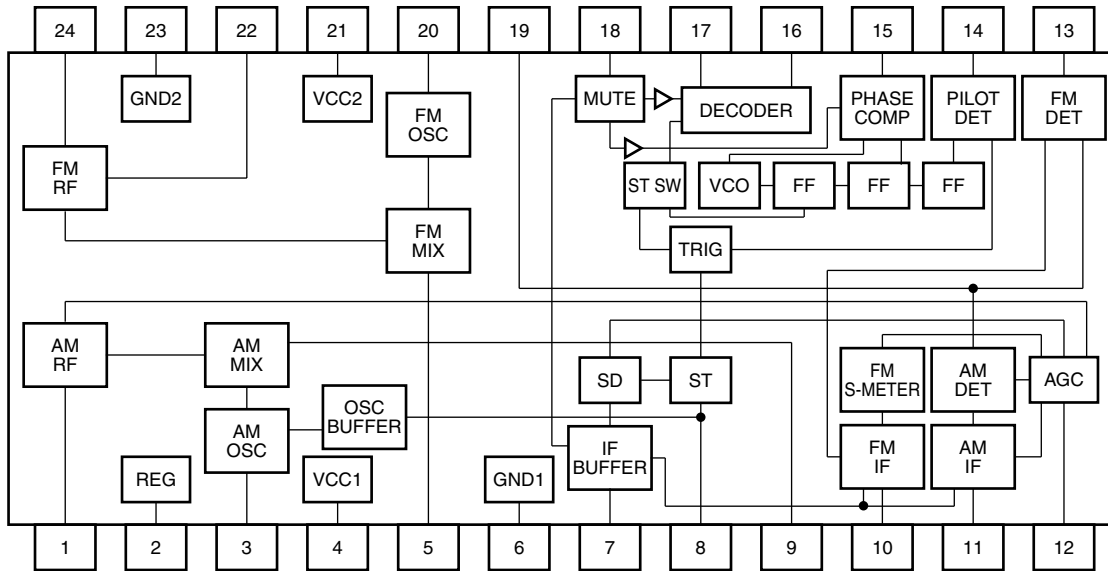

2. Pin function

Pin No.	Symbol	I/O	Function	Pin No.	Symbol	I/O	Function
1	AM_RF IN	I	AMRF signal input	13	FM_DET	O	FM detection signal output
2	REG.	-		14	ST/MON_SW	I	Stereo/Monaural switching signal input
3	AM_OSC	-	AM local oscillation circuit	15	AM/FM_SW	I	AM/FM switching signal input
4	VCC_1	-	Power supply terminal	16	L_OUT	O	Output L-channel
5	FM_MIXOUT	O	Output terminal for FM mixer	17	R_OUT	O	Output R-channel
6	GND_1	-	Ground	18	MPX_IN	I	Multiplex signal input
7	IF_BUFFER	O	IF buffer output	19	DET_OUT	O	AM/FM detection output
8	ST_IND	O	Stereo indicator output	20	FM_OSC	-	FM local oscillation circuit
9	AM_MIXOUT	O	Output terminal for AM mixer	21	VCC_2	-	Power supply terminal
10	FM_IF IN	I	Input of FMIF signal	22	FM_RFOUT	O	Output of FMRF signal
11	AM_IF IN	I	Input of AMIF signal	23	GND_2	-	Ground
12	AGC	I	AGC voltage input terminal	24	FM_RF IN	I	Input of FMRF signal

■ LC72136N (IC2) : PLL Frequency synthesizer

1. Terminal layout

XTI	1	22	\overline{XT}
FM	2	21	GND
CE	3	20	LPFI
DI	4	19	LPFO
CLOCK	5	18	PD
DO	6	17	VCC
VCOSTOP	7	16	FMIN
AM/FM	8	15	AMIN
LW	9	14	NC
MW	10	13	IFCNT
SDIN	11	12	IFIN

2. Block diagram

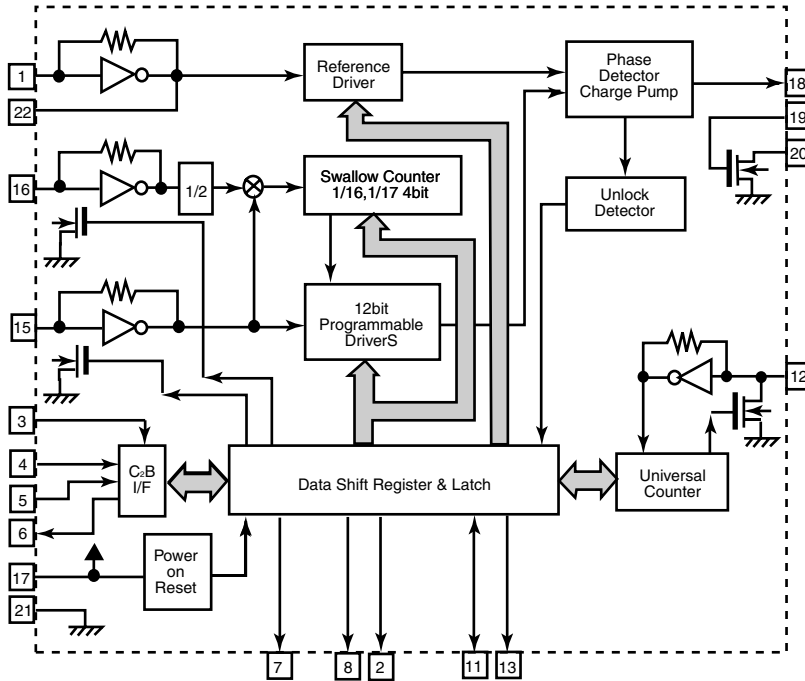

3. Pin function

Pin No.	Symbol	I/O	Function	Pin No.	Symbol	I/O	Function
1	XTI	I	X'tal oscillator connect (75KHz)	12	IFIN	I	IF counter signal input
2	\overline{FM}	O	LOW:FM mode	13	IFCNT	O	IF signal output
3	CE	I	When data output/input for 4pin(input) and 6pin(output): H	14	NC	-	Not use
4	DI	I	Input for receive the serial data from controller	15	AMIN	I	AM Local OSC signal output
5	CLOCK	I	Sync signal input use	16	FMIN	I	FM Local OSC signal input
6	DO	O	Data output for Controller Output port	17	VCC	-	Power supply(VDD=4.5~ 5.5V) When power ON:Reset circuit move
7	VCOSTOP	O	"Low": MW mode	18	PD	O	PLL charge pump output(H: Local OSC frequency Height than Reference frequency. L: Low Agreement: Height impedance)
8	AM/FM	O	Open state after the power on reset	19	LPFO	O	Output for active lowpassfilter of PLL
9	NC	-	Input/output port	20	LPFI	I	Input for active lowpassfilter of PLL
10	NC	-	Input/output port	21	GND	-	Connected to GND
11	SDIN	I/O	Data input/output	22	\overline{XT}	I	X'tal oscillator(75KHz)

■ TA8189N (IC401) : REC/PB amp.

1. Terminal layout

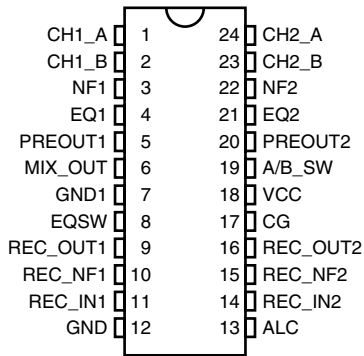

2. Block diagram

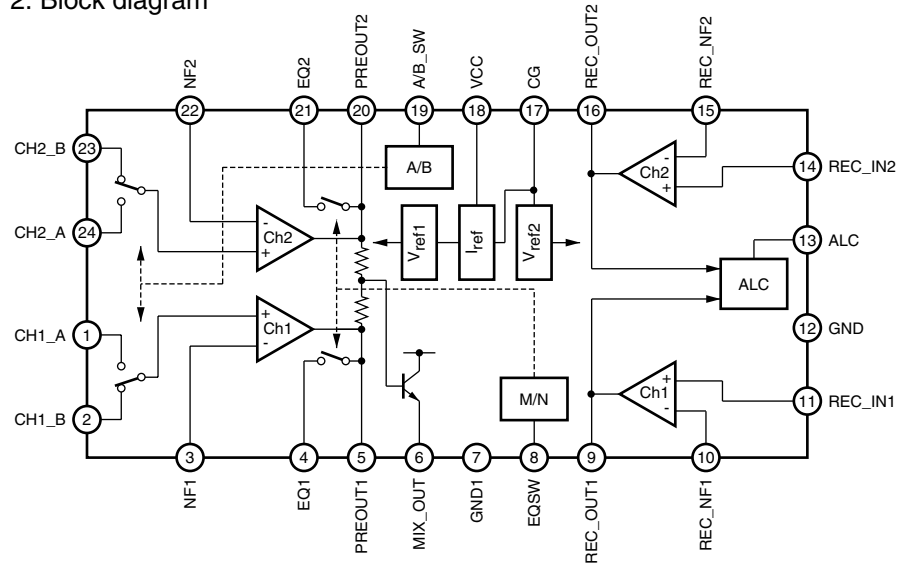

3. Pin function

Pin No.	Symbol	I/O	Function	Pin No.	Symbol	I/O	Function
1	CH1_A	I	Input for playback amp. (Ch1): A cassette (PB)	13	ALC	I	ALC filter terminal
2	CH1_B	I	Input for playback amp. (Ch1): B cassette (REC/PB)	14	REC_IN2	I	Input for recording amp.
3	NF1	I	NF terminal for playback amp.	15	REC_NF2	I	NF terminal for recording amp.
4	EQ1	O	Metal output for playback amp.	16	REC_OUT2	O	Output for recording amp.
5	PREOUT1	O	Output terminal for playback amp.	17	CG	O	Charge detection terminal
6	MIX_OUT	O	Mixing output	18	VCC	-	Power supply terminal
7	GND1	-	Ground	19	A/B_SW	I	REC amp. Select switch (A cassette/B cassette)
8	EQSW	I	Metal/Normal mode select switch	20	PREOUT2	O	Output terminal for playback amp.
9	REC_OUT1	O	Output for recording amp.	21	EQ2	O	Metal output for playback amp.
10	REC_NF1	I	NF terminal for recording amp.	22	NF2	I	NF terminal for playback amp.
11	REC_IN1	I	Input for recording amp.	23	CH2_B	I	Input for playback amp. (Ch2): B cassette (REC/PB)
12	GND1	-	Ground terminal	24	CH2_A	I	Input for playback amp. (Ch2): A cassette (PB)

■ TC74HC4094AP (IC402) : 8-bit shift and store resistor

1. Terminal layout

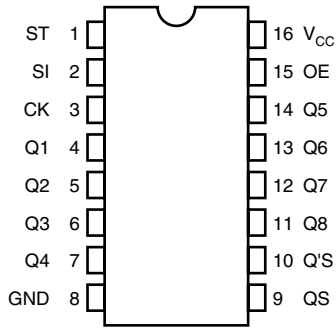

2. Block diagram

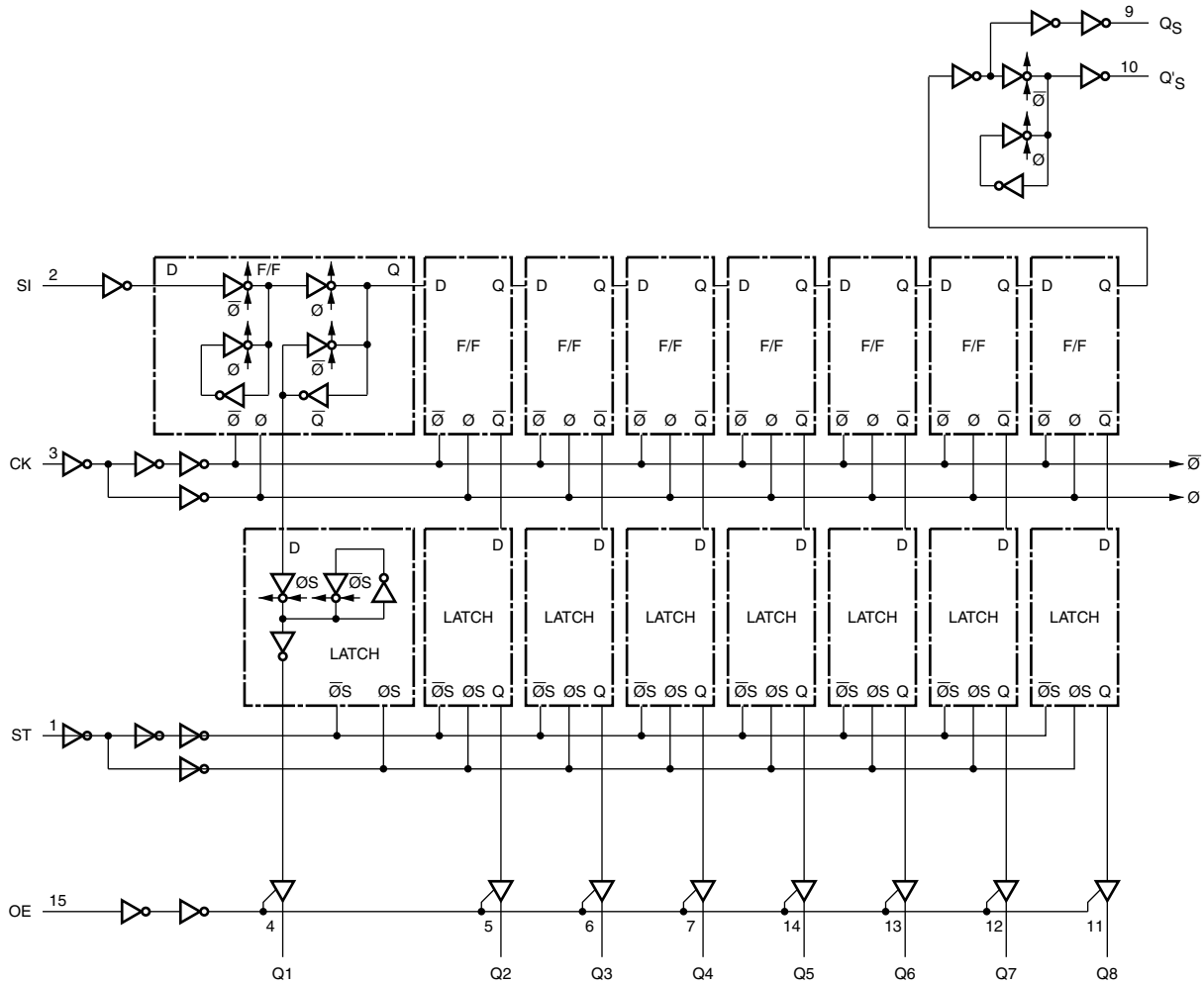

■ TDA7440D (IC101) : Audio processor

1. Terminal layout

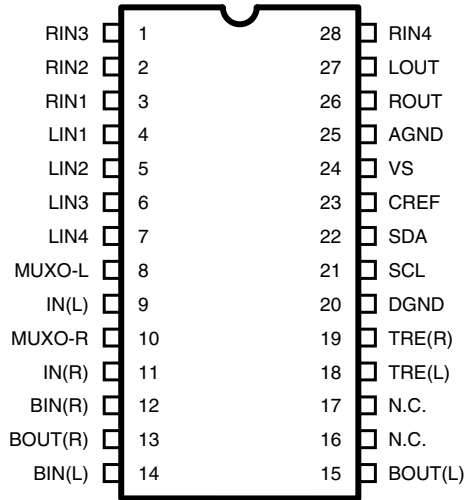

2. Block diagram

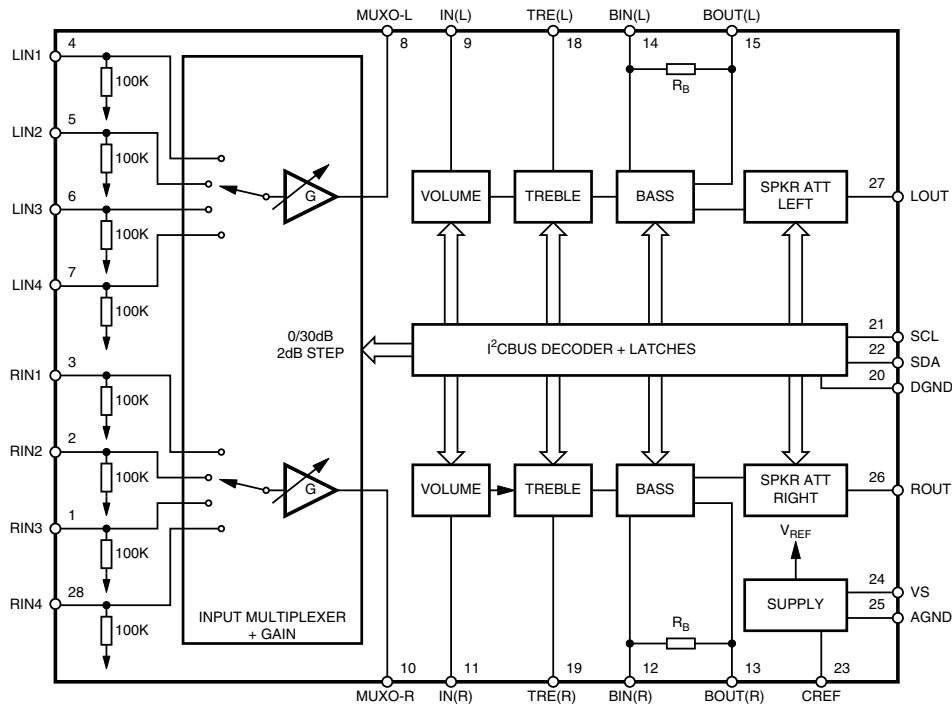

■ MN662748RPM (IC601) : Digital servo & digital signal processor

1. Terminal layout

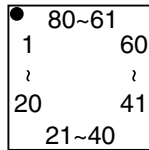

2. Pin function

Pin No	Symbol	I/O	Function	Pin No	Symbol	I/O	Function
1	BCLK	-	Not use	41	PLL2	-	Not use
2	LRCK	-	Not use	42	TOFS	-	Not use
3	SRDATA	-	Not use	43	WVEL	-	Not use
4	DVDD1	-	Power supply for digital circuit	44	ARF	I	RF signal input
5	DVSSI	-	GND for digital circuit	45	IREF	I	Reference current input
6	TX	-	Not use	46	DRF	I	Bias pin for DSL
7	MCLK	I	Micro computer command clock signal input	47	DSL	I/O	Loop filter pin for DSL
8	MDATA	I	Micro computer command data input	48	PLL	I/O	Loop filter pin for PLL
9	MLD	I	Micro computer command load signal input (L: Load)	49	VCOF	I/O	Loop filter pin for VCO
10	SENSE	-	Not use, connect to TP7	50	AVDD2	-	Power supply for analog circuit
11	FLOCK	-	Not use, connect to TP6	51	AVSS2	-	GND for analog circuit
12	TLOCK	-	Not use, connect to TP5	52	EFM	-	Not use, connect to TP12
13	BLKCK	O	Sub code block clock signal output	53	PCK	O	Clock output for PLL
14	SQCK	I	External clock input for sub code Q register input	54	VCOF2	I/O	Loop filter pin for Digital servo VCO
15	SUBQ	O	Sub code Q data output	55	SUBC	-	Not use
16	DMUTE	I	Muting input (H: Mute)	56	SBCK	-	Not use
17	STAT	O	Status signal input	57	VSS	-	GND for crystal oscillation circuit
18	RST	I	Reset signal input (L: Reset)	58	X1	I	Input for crystal oscillation circuit (f=16.9344MHz)
19	SMCK	-	Not use	59	X2	O	Output for crystal oscillation circuit (f=16.9344MHz)
20	PMCK	-	Not use, connect to TP8	60	VDD	-	Power supply for crystal oscillation circuit
21	TRV	O	Traverse enforced output	61	BYTCK/TRVSTP	-	Not use
22	TVD	O	Traverse drive output	62	CLDCK	O	Sub code frame clock signal output
23	PC	-	Not used	63	FCLK	-	Not used
24	ECM	O	Spindle motor drive signal (Enforced mode output)	64	IPFLAG	O	Interpolation flag signal output, Connect to TP11
25	ECS	O	Spindle motor drive signal (Servo error signal output)	65	FLAG	O	Flag signal output, Connect to TP10
26	KICK	O	Kick pulse output	66	CLVS	-	Not use
27	TRD	O	Tracking drive output	67	CRC	-	Not use
28	FOD	O	Focus drive output	68	DEMPH	O	De-emphasis detect signal output, Connect to TP9
29	VREF	I	Reference voltage for D/A output block	69	RESY	-	Not use
30	FBAL	O	Focus balance adjust signal output	70	IOSEL	I	Mode select pin, Connect to DVDD1 (H fix)
31	TBAL	O	Tracking balance adjust signal output	71	/TEST	I	Test pin, Connect to DVDD1 (H fix)
32	FE	I	Focus error signal input (Analog input)	72	AVDD1	-	Power supply for analog circuit
33	TE	I	Tracking error signal input (Analog input)	73	OUTL	O	L-channel audio output
34	RFENV	I	RF envelope signal input (Analog input)	74	AVSS1	-	GND for analog circuit
35	VDET	I	Vibration detect signal input (H:Detect)	75	OUTR	O	R-channel audio output
36	OFT	I	Off track signal input (H:Off track)	76	RSEL	I	RF signal polarity setting pin, Connect to DVDD1 (H fix)
37	TRCRS	I	Track cross signal input	77	CSEL	I	Oscillation frequency setting pin, Connect to GND (L fix)
38	/RFDET	I	RF detect signal input (L:Detect)	78	PSEL	I	IOSEL=H, Test pin, Connect to GND (L fix)
39	BDO	I	Drop out signal input (H:Drop out)	79	MSEL	I	IOSEL=H, SMCK output, Frequency select pin
40	LDON	O	Laser on signal output (H:ON)	80	SSEL	I	IOSEL=H, SMCK output, SUBQ output mode select pin

■ TDA7295 (IC101, IC201) : Audio amplifier

1. Terminal layout

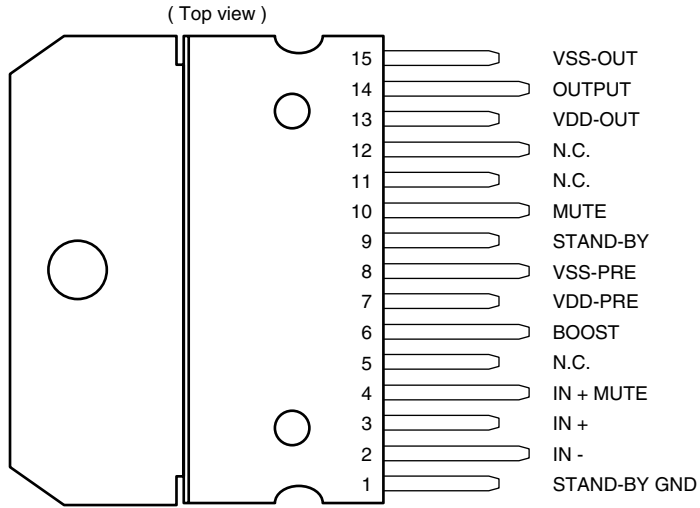

2. Block diagram

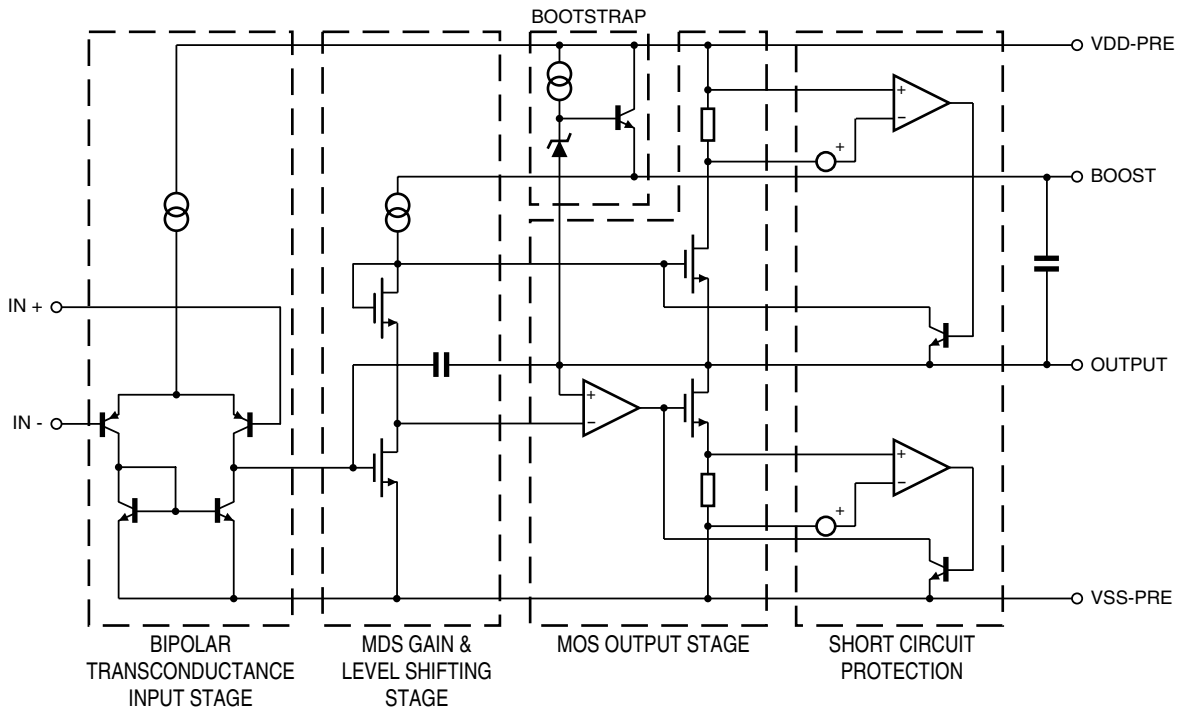



VICTOR COMPANY OF JAPAN, LIMITED

AUDIO & COMMUNICATION BUSINESS DIVISION

PERSONAL & MOBILE NETWORK B.U. 10-1, 1Chome, Ohwatari-machi, maebashi-city, 371-8543, Japan